

PAM

VertiQuench

UCB

JetCaster

Vortex®

4D Quench

VIM

Super IQ

EB

Vector 3D

Pit -LPC

ZeroFlow

SECO/WARWICK

INVENTION MEETS RELIABILITY

CMe

/ CONTENTS:

01. Mission and vision	03	07. Customers are our references	28
02. Roots	05	08. Team = value	30
03. What we build	07	09. We have values in our DNA	33
04. The expert in metal heat treatment	19	10. Socially responsible	35
05. What sets us apart	21	11. We support	37
06. Who we build for	26	INVENTION MEETS RELIABILITY	43

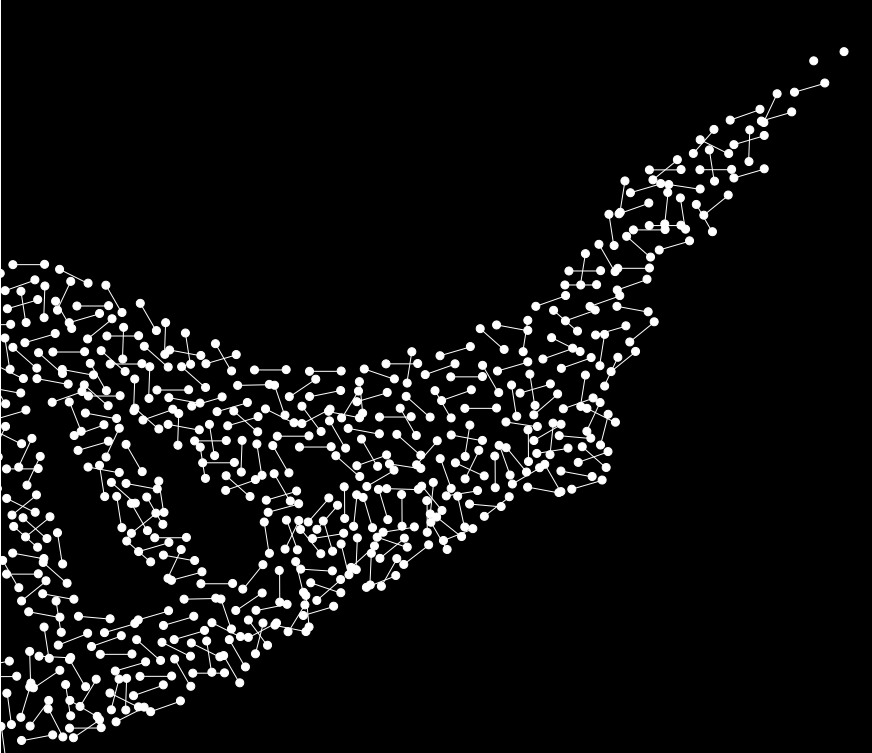

Just like people, companies are organisms that reflect their creators, the environment in which they grow, the obstacles that appear in their path, and the strengths that allow them to be successful. Organisms carry a set of core principles and values providing information about the actions and the results of their work. In short, they have their DNA and, encoded within, their values. In these lie the answers to the two simple, yet most difficult and important questions: who they are as a company, and why it matters.





KIM JESTEŚMY

MISSION

The mission tells us why we exist, for whom we do what we do, why we do it, and what the purpose of the company's existence is.

Thanks to the experience and expertise of our employees as well as cooperation with business partners, we create innovative products that give our customers reliable, safe, and environmentally friendly heat treatment and metallurgy solutions ensuring the economic efficiency of their business.

VISION

The vision is our dream, inspiration, encouragement, stimulus, signpost.

We want to be the first-choice provider of heat treatment and metallurgy solutions. Innovation and reliability are evident in the way we think and create anywhere in the world.

ROOTS

It all started in America.

At the turn of the 20th century, the Chicago Flexible Shaft Company decided to expand its product line. John Stewart took on the challenge of developing a heat treatment furnace for tempering steel to modernize the manufacturing process in order to increase product quality and production efficiency. Soon other Chicago companies asked for the development of these systems for themselves, and that was how the Stewart Furnace Division was born. The Chicago Flexible Shaft Company was building on its success and decided to add home appliances to its range, creating the trade name "Sunbeam".

The furnace group became known as the Sunbeam Stewart Furnace Company, remaining so until the late 1950s when the name was changed to Sunbeam Equipment Corporation, and later

became part of the industrial group that included the John Warwick Furnace Company.

The new owners were faced with the dilemma of how to present their new company without losing their loyal customer base and good reputation for service. They decided to combine the names Sunbeam Equipment Corporation and Warwick, thus forming the SECO/WARWICK Corporation in Meadville, Pennsylvania. The year was 1984. Looking for new opportunities for development, SECO/WARWICK reached out to Europe. Specifically, Poland where in 1991 a joint venture was established with Trans-VAC. The company then continued to grow by acquiring further companies including the Polish company Elterma, the British Camlaw, and the American Retech together with their intellectual property. Branches started opening around the world.

- 1920**
The Sunbeam
- 1950**
John Warwick Furnace Company
Elterma
- 1963**
Retech
- 1970**

1991

The joint venture SECO/WARWICK Sp. z o.o. starts operating in Poland

2002

Acquisition of intellectual property of CAMLAW Ltd.

2003

Acquisition of ELTERMA S.A.

2004

Establishment of the branch in Moscow

2005

Entrance into the Chinese market

2007

Initial Public Offering on the Warsaw Stock Exchange



All these events shaped the company in terms of technology, the way we conduct business, customer cooperation, and the direction of development. Today, SECO/WARWICK Group (9 companies in Poland, Germany, Russia, China, India, the U.S., and 3 brands: Retech, SECO/VACUUM TECHNOLOGIES (SVT), and SECO/WARWICK) has a strong foundation allowing it to be a technological hub for heat treatment and vacuum metallurgy.

FROM A PASSION FOR SEEKING NEW SOLUTIONS TO A TRENDSETTER

2010

Retech LLC becomes the property of SECO/WARWICK

2014

Establishment of SECO/WARWICK Germany

2016

Creation of SECO/WARWICK Services

2017

Establishment of SECO/VACUUM TECHNOLOGIES. Creation of SECO/WARWICK System & Services (INDIA) Pvt. Ltd.

2019

Appointment of SECO/WARWICK Group's new CEO – Sławomir Woźniak

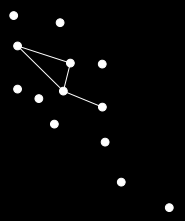

WHAT WE BUILD

For over 100 years, the SECO/WARWICK Group has been building the global heat treatment and metallurgy industry by providing industrial furnaces for leading companies in the following sectors: aviation, automotive, machinery, medical, toolmaking, power, and commercial heat treatment.

The company specializes in end-to-end solutions in 5 categories: vacuum heat treatment, aluminum thermal processing, atmosphere thermal processing, brazing of heat exchangers, and vacuum metallurgy.

Our solutions help to produce control system components, gears, aircraft landing systems, turbines, aircraft engine blades, plane and car heat exchangers, surgical instruments, and coins, as just a few examples of heat treatment and metallurgy applications.

We give our customers reliable, safe, and environmentally friendly solutions for heat treatment and metallurgy that ensure the economic efficiency of their business. As Albert Einstein used to say, *problems cannot be solved with the same thinking that was used to create them*. That is why at SECO/WARWICK we create and implement technologies that break generally accepted rules and stereotypes.

01.



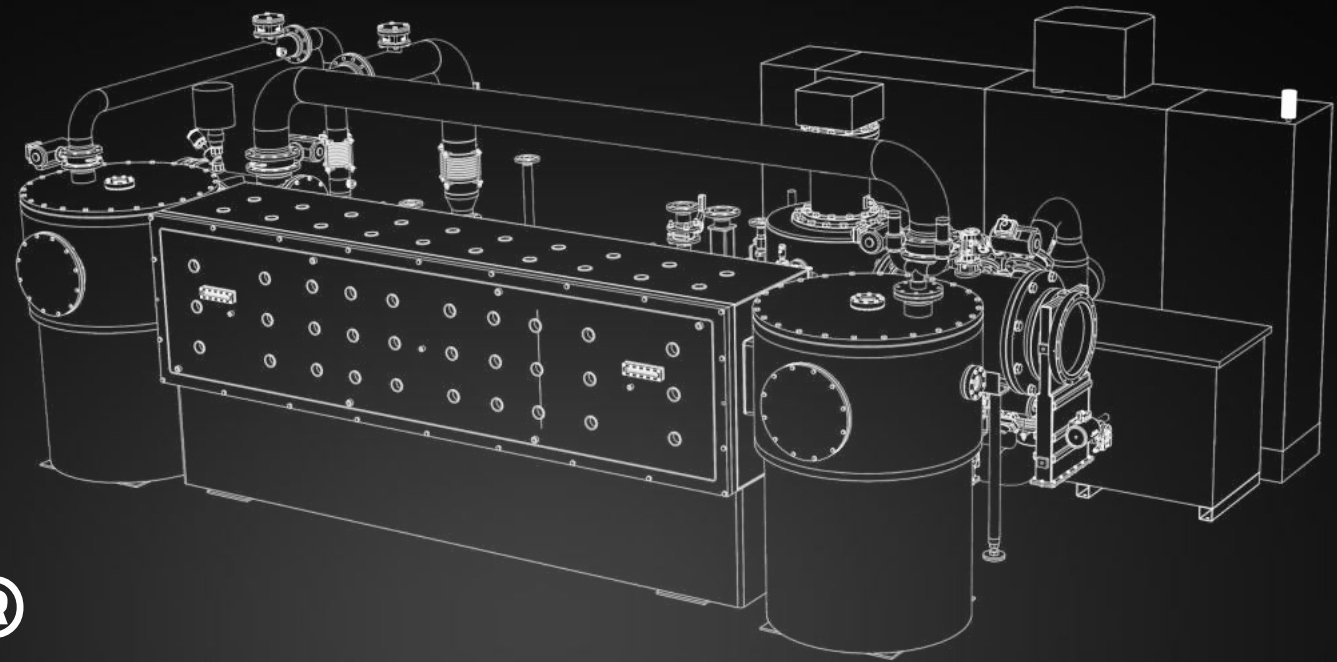
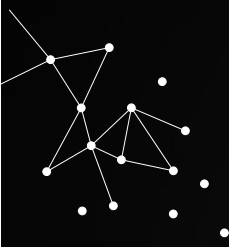

4D Quench®

The 4D Quench® is the answer to the current needs of the most demanding industries in terms of quality and repeatability of quenching results as well as minimization and control of quenching deformations. It is designed for single-piece flow quenching in high-pressure gas, for all those who are looking for a better alternative to press quenching.

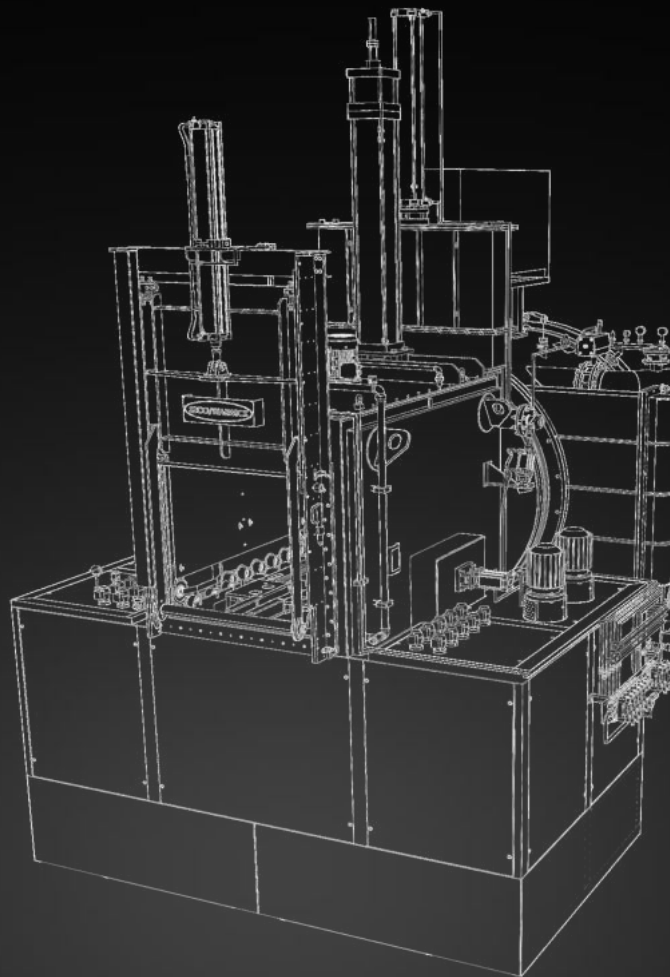

Super IQ®

The Super IQ® is a hybrid system combining, in a single furnace, the best traits of a conventional furnace and a vacuum furnace. It is primarily designed for carburizing processes at elevated temperatures, and for hardening.

The industry demands a cleaner, faster and, above all, more effective method of carburizing. In comparison with traditional methods, the Super IQ® offers advantages in terms of improved productivity. It operates in higher temperature ranges, which translates into shorter cycles and this, in turn, into more efficient production.

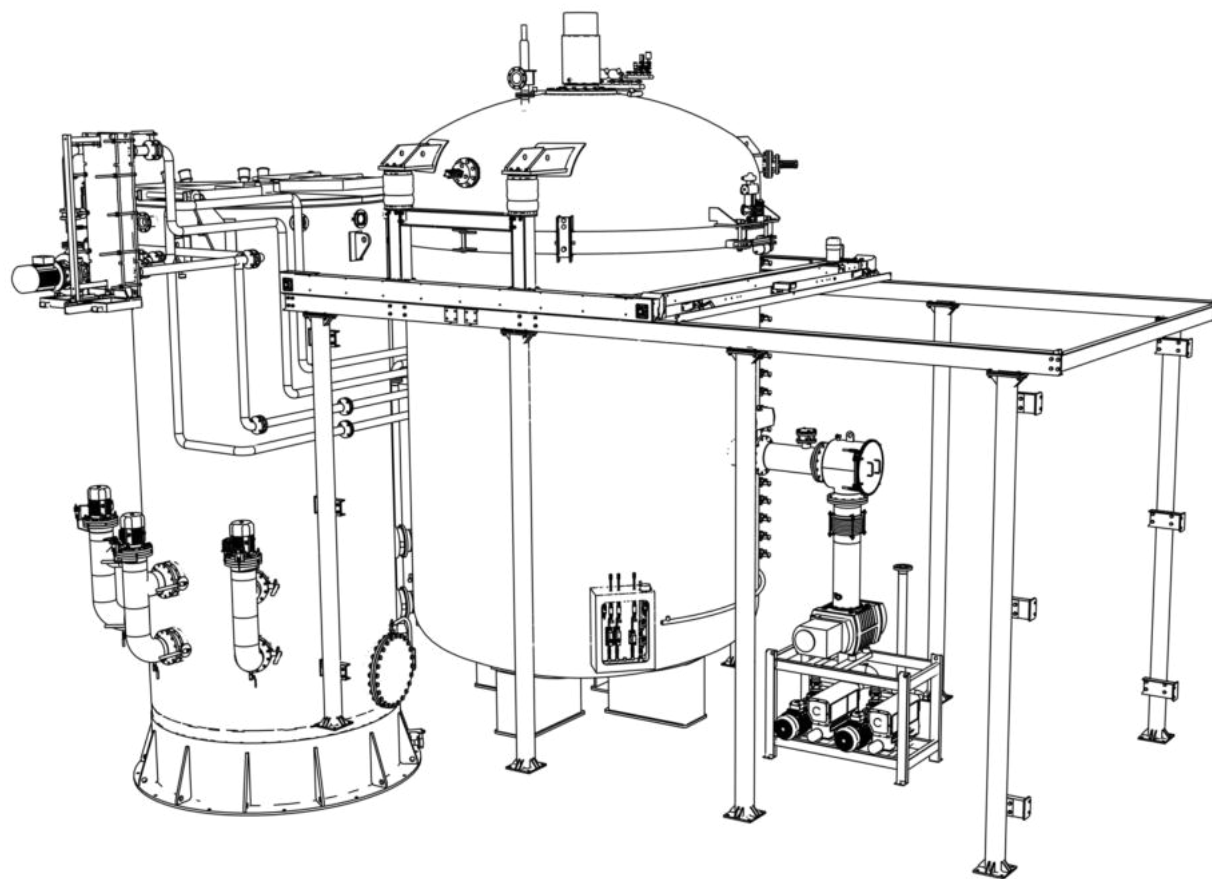

Pit-LPC®

Effective and efficient carburizing, excellent quality – at reduced process and running costs. The ideal solution for manufacturers carburizing massive or longitudinal elements such as gearwheels, bearings, drilling tools, and other elements that require thick carburized layers. The applied LPC technology allows high homogeneity of process parameters, which has an effect on the thickness of the carburized layer and on the quality of the processed detail. Pit-LPC is characterized by a minimal consumption of process gases, no flammable or explosive atmosphere, and low heat emissions.

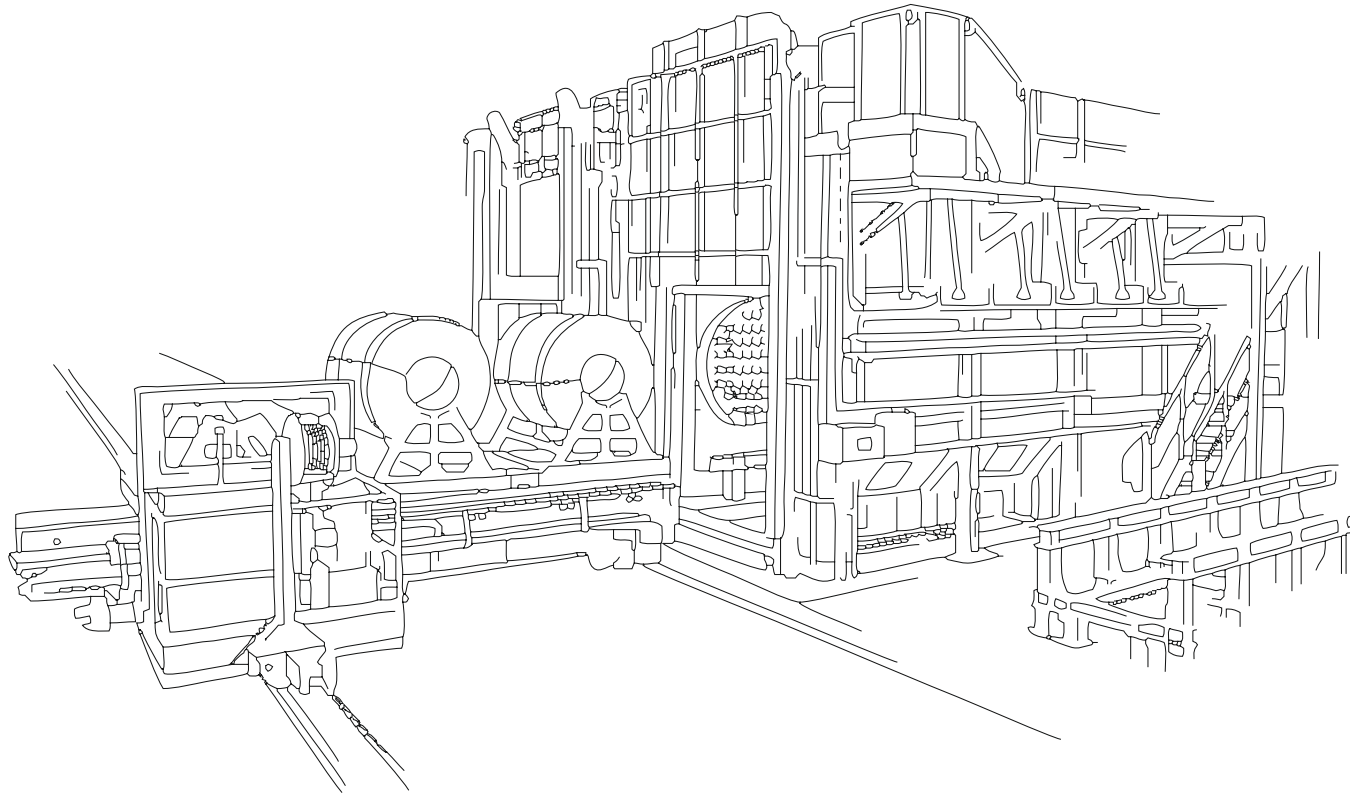

Vortex®

The patented High Convection Jet Heating System is designed for heating coils of aluminum sheet during the dual processes of inter-operation annealing and final annealing. This energy-saving and efficient system is based on specially shaped nozzles that generate a spiral flow of the heating medium, in combination with a powerful fan and a unique system of baffles. Furnaces fitted with the Vortex® system make it possible to shorten the time necessary to heat up the material without the risk of overheating it. As a result, these furnaces are more productive than other solutions seen on the market.

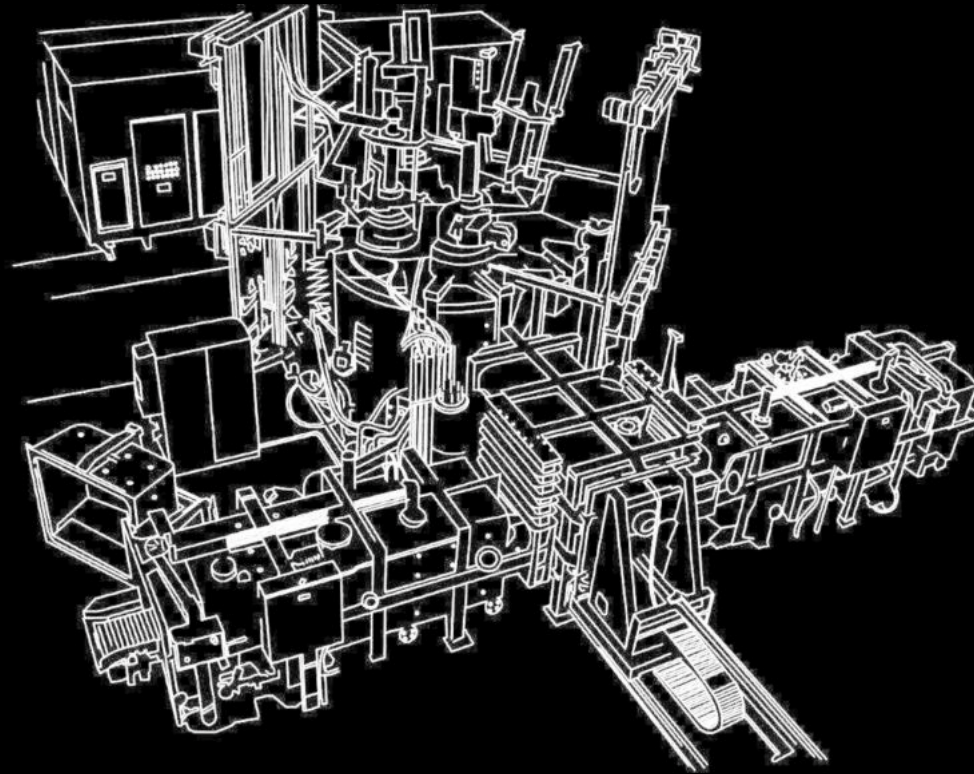
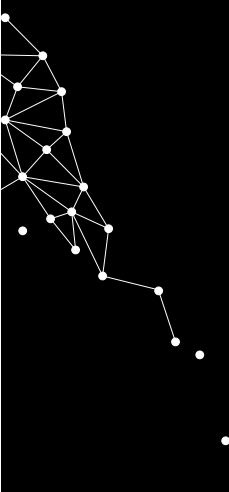

PAM®

This melting furnace uses a plasma arc that ensures a significant improvement in the properties of alloys and offers the possibility of developing and producing new complex alloys.

Melting takes place in a protective atmosphere (usually helium or argon), in a sealed chamber. The furnace hearth is free of elements that would contaminate the alloy (such as oxygen) and, thanks to its design, produces a 'clean' casting by eliminating inclusions of both high and low density. PAM spans a wide range of equipment – from small laboratory furnaces with a capacity of a few kilograms, all the way to multi-ton production furnaces.

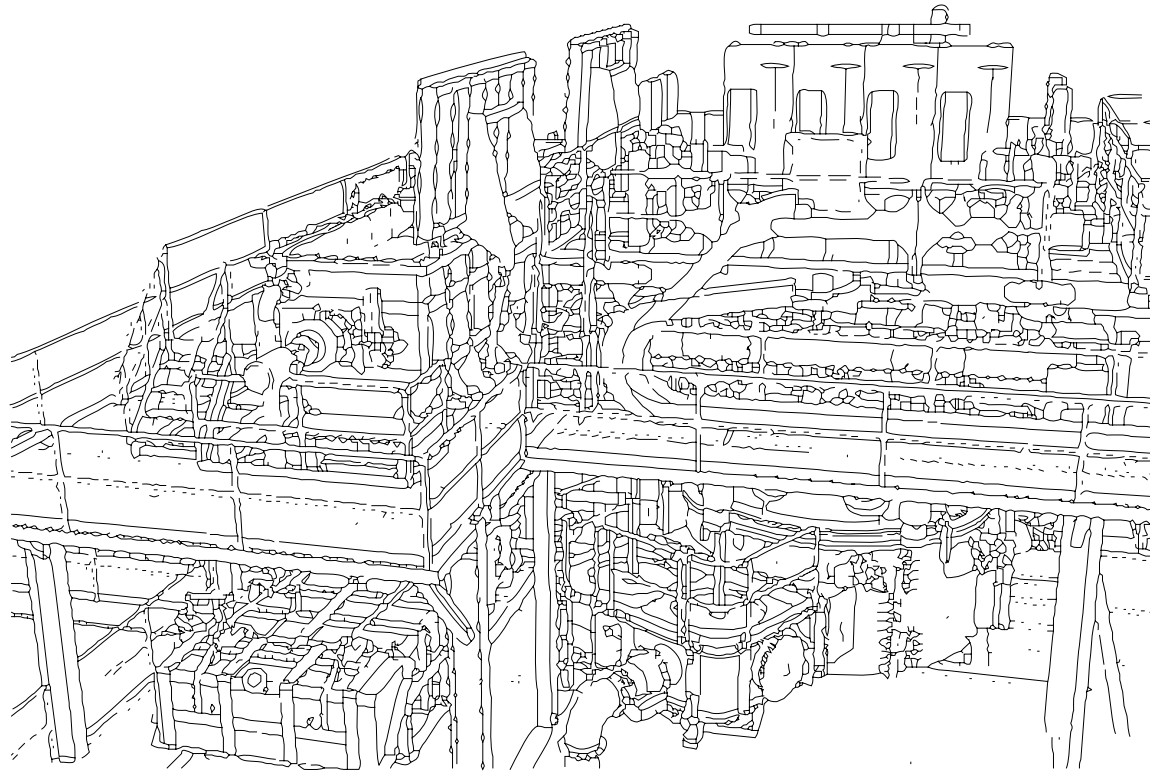

EB®

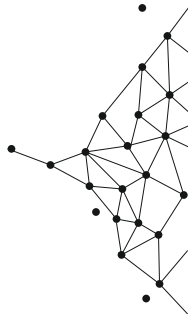

The EB Equipment is a technology where the melting process is carried out by means of an electron beam. This system allows for the effective refining of the melted metal and offers a high degree of flexibility in the heat source. It is therefore the perfect way to melt and refine metals and their alloys under high-vacuum conditions, in water-cooled copper crucibles.

EB melting systems are designed for the production of high-quality ingots and bars from raw and/or refined material. The fed material can also be ingots previously melted in a VAR furnace (primary melting). At present, this process is mainly used for the processing of high-temperature creep resistant metals and reactive metals (tantalum, niobium, molybdenum, tungsten, vanadium, hafnium, zirconium, titanium) and their alloys. An EB melting system is therefore used primarily for recycling titanium scrap as well as the consolidation of melted metals.

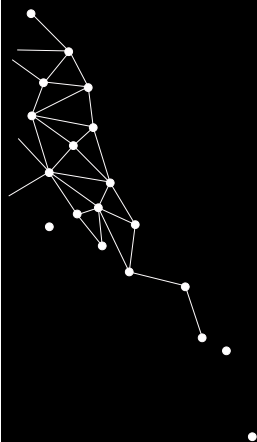

VIM

A VIM furnace is used for the production of high-quality precision castings, most often the blades of power turbines and plane turbines made of superalloys.

This technology is the top solution in the segment of melting equipment.

Depending on the working parameters of the castings, the furnace can be designed for the production of equiaxed blades (EQ), directionally solidified blades (DS), and single-crystal blades (SC) that meet the most stringent requirements.

Highly accurate measurement systems and precise drives combined with a modern intuitive control system ensure repeatability of processes and satisfaction of the demanding requirements of the aviation industry.

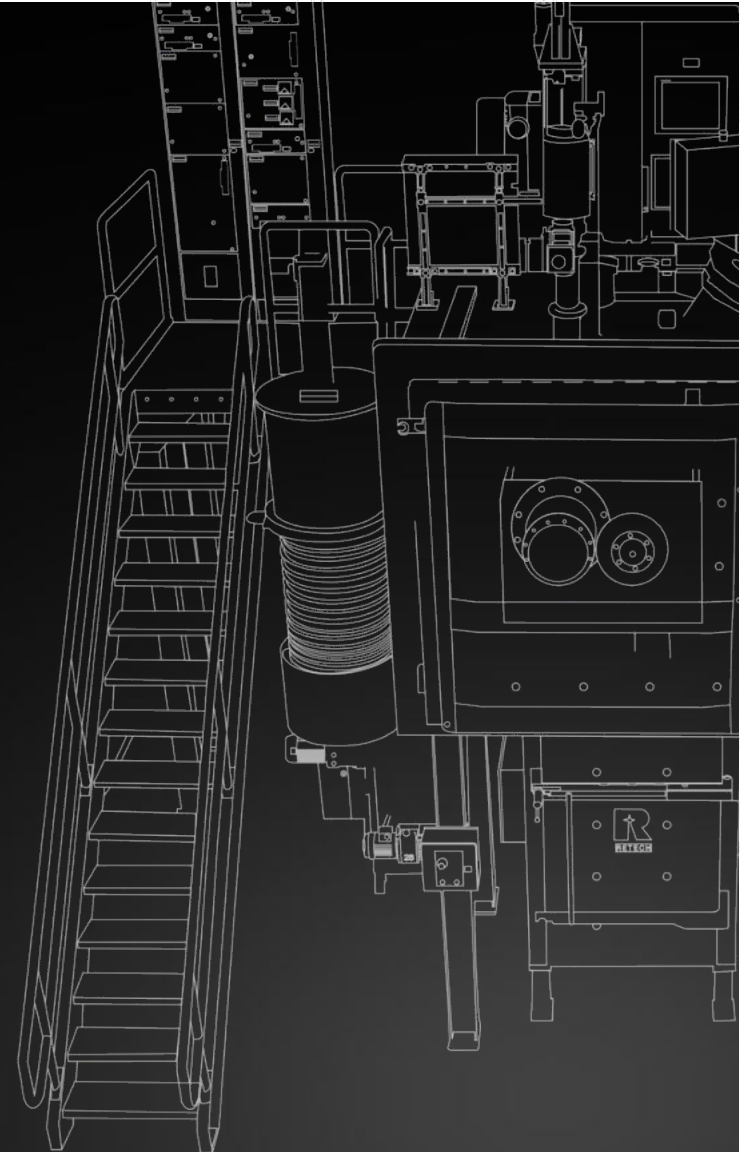

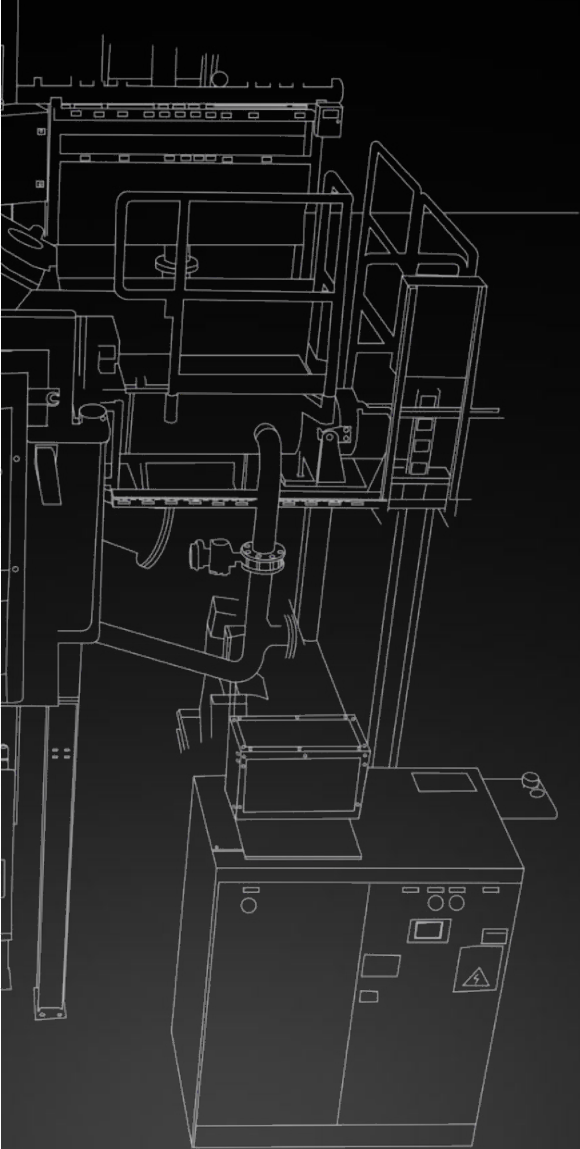

JetCaster

This innovative vacuum casting furnace opens up a number of new possibilities in the field of single-crystal casting nickel and cobalt superalloys. The applied single-crystal casting technology allows us to build a unit fitted with a casting cooling system that uses a supersonic argon stream, and to offer the following features: possible operation in SC/DS/EQ modes, significantly increased speed of removing single-crystal castings, non-contact measurement of the temperature gradient in the crystallization front area with automatic mold removal speed control, low percentage of casting defects (both macro- and micro-structural), possibility of double or triple shortening of the single-crystal casting process.

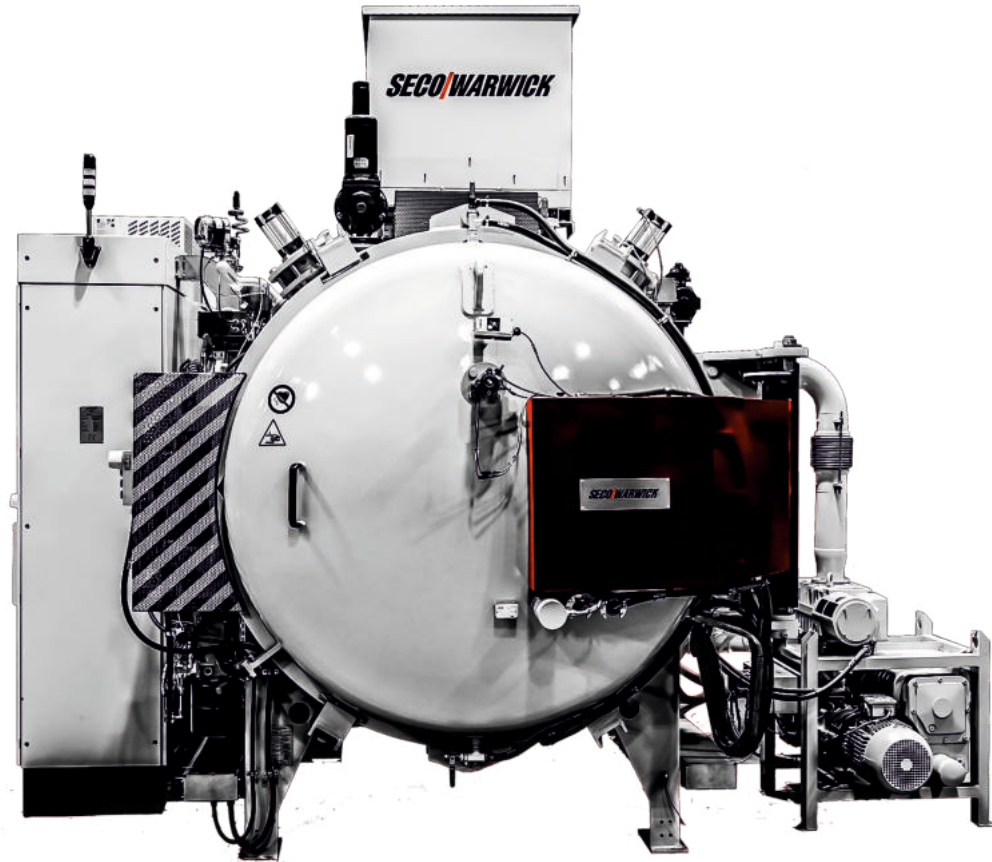

Vector 3D

The Vector 3D is a line of industrial-application furnaces designed specifically to support 3D printing processes for metal and alloy elements. Additive manufacturing is no longer just a scientific concept, but a real growing industry that poses new challenges in the field of heat treatment. Debinding systems, increased process purity, and ideal temperature distribution are just some of the key features of the dedicated Vector 3D product line offered by SECO/WARWICK.

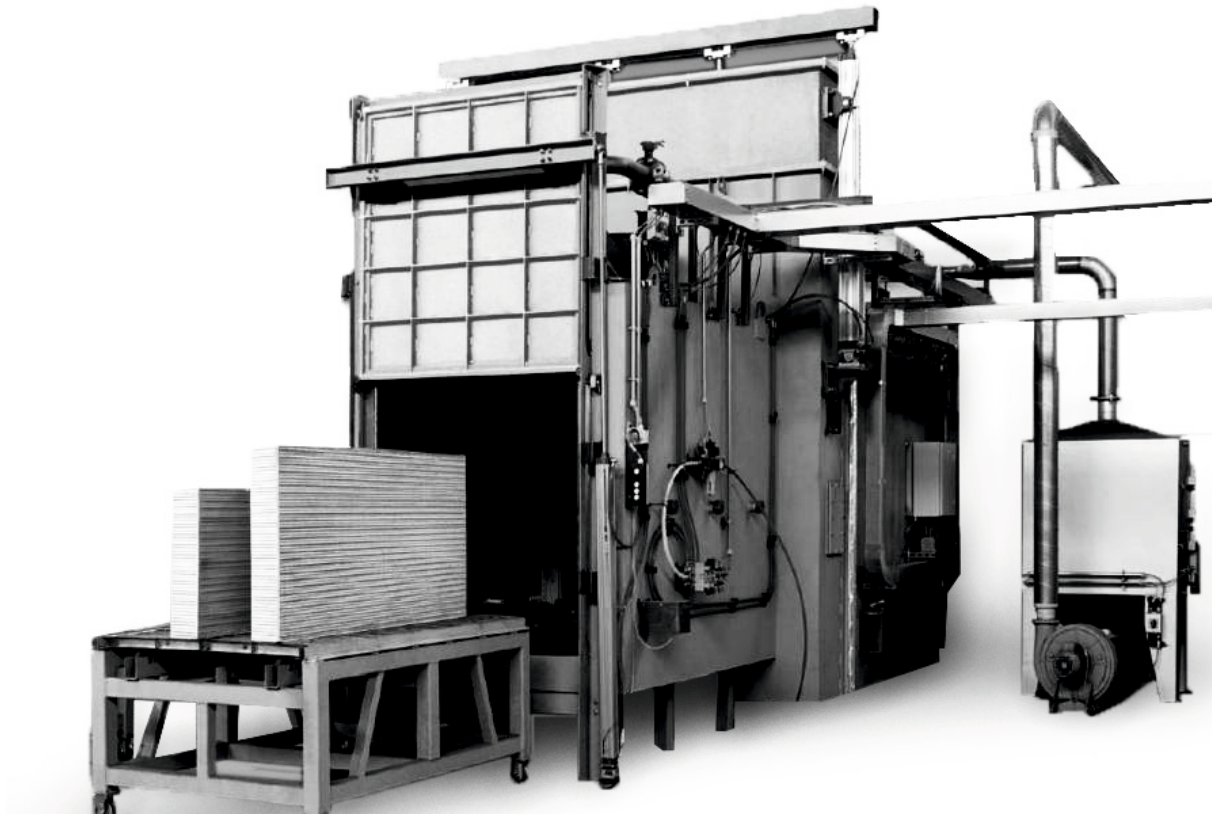

Universal CAB Batch Furnace

A universal chamber furnace means high quality brazing during low volume production. This type of furnace is intended for brazing a wide range of heat exchangers in either a horizontal or vertical position, depending on the requirements related to their design. It allows users to manufacture top quality products with both standard and vacuum flushing options. In an extremely short time, the furnace can be heated from ambient temperature to brazing temperature maintaining the correct atmosphere inside. The chamber furnace provides different heating and cooling speeds, depending on the product requirements.



THE EXPERT IN METAL HEAT TREATMENT TECHNOLOGY

At SECO/WARWICK, we approach each project individually – often, the customer is looking for a solution that requires cooperation between different segments. Knowing what the customer needs, we select the best technology and solution together with experienced experts.

Application: for over 100 years we have been meeting the most stringent requirements of the industry and renowned customers, solving the most difficult technical/process tasks, and achieving success worldwide.

Industry: Wherever there is heat treatment and metallurgy, there are our solutions.

Unique features: energy-efficient and environmentally friendly equipment, access to new solutions and technologies that we ourselves define, state-of-the-art control and data analysis systems, and professional maintenance services available in every part of the world.

Technologies: those that give the best results. Our partners have access to the knowledge, experience, technology, and specialists in the fields of engineering and science who look for the best solutions

Scope: standard and dedicated solutions, delivery of equipment including process and auxiliary equipment, installation and start-up, maintenance service, technical and process training, trials and tests under industrial and laboratory conditions, analyses and simulations.

The solutions of SECO/WARWICK also include furnaces for carrying out fireproof tests, vacuum equipment, chambers for performing precision tests, thermal processing systems, production lines for heating and forming car windshields, and custom solutions that allow us to gain an advantage over our competitors.

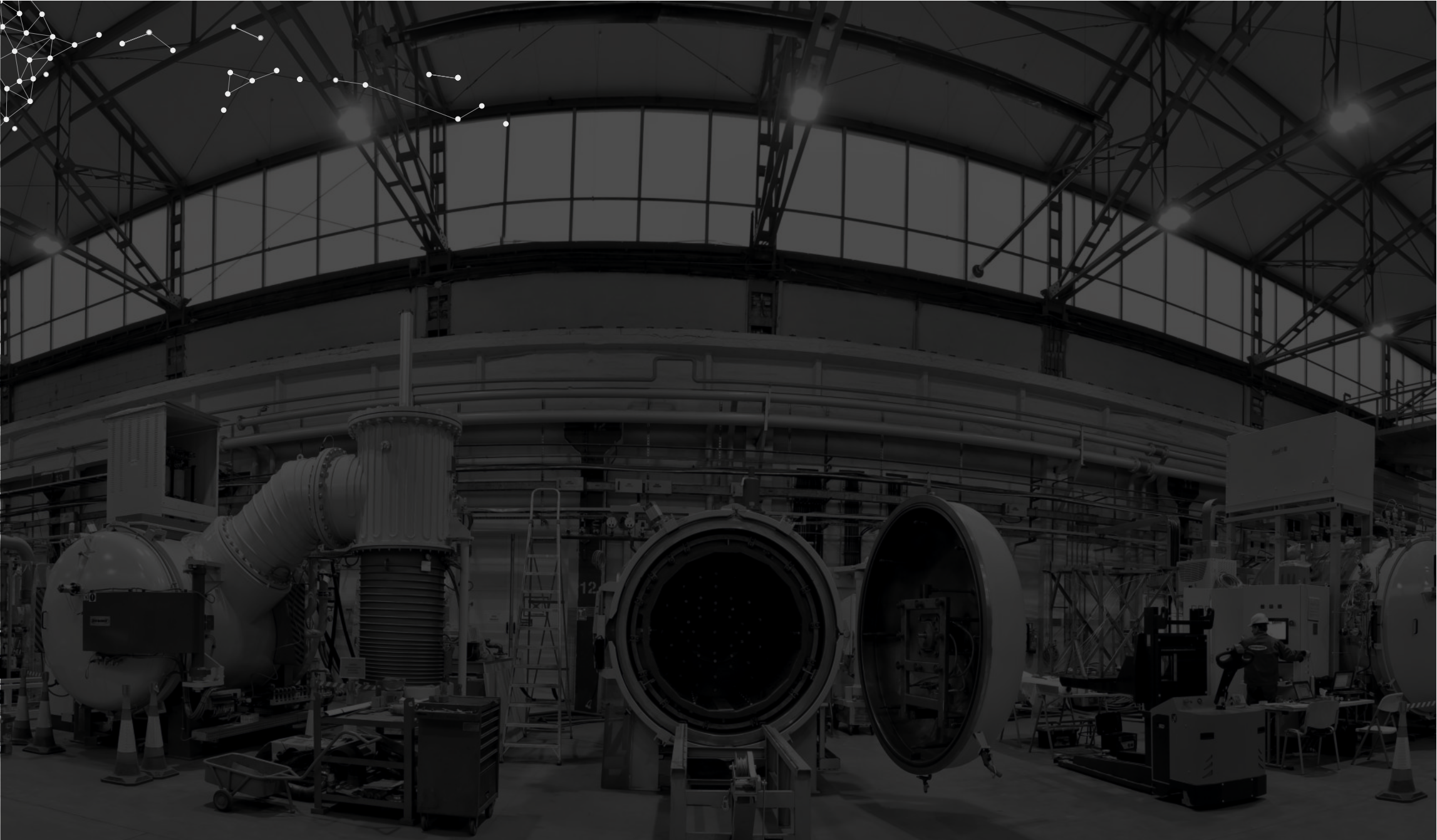

At SECO/WARWICK, each project is approached individually – often, the customer is looking for a solution that requires cooperation between different segments. Knowing what the customer needs, we select the best technology and solution together with experienced experts.

SECO/WARWICK

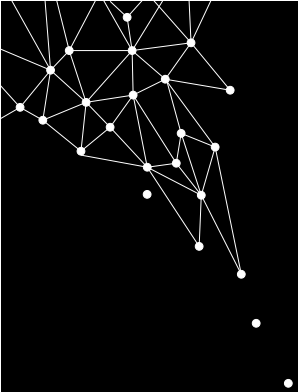

WHAT SETS US APART

The power of SECO/WARWICK Group is the power of its innovation, measured by the distance between our company and its competitors. It can also be measured by the number of patents and trademarks, completed projects, and the long list of references and customers around the world.

At SECO/WARWICK, patents are not just about statistics (there are more than 50 of them!). These inventions are well-thought-out and strongly customer-oriented solutions, thanks to which the company is gaining a significant advantage over its competition. SECO/WARWICK's patented inventions and solutions in the fields of vacuum furnaces, vacuum carburizing technology, and aluminum annealing furnaces, for example,, are successfully applied and realized in the daily work of customers worldwide.

Award-Winning Leader of Innovation

We have received a number of prestigious awards and distinctions recognized in the industry and in the world of business in appreciation of our extensive research and development activities (INNOVATION LEADER, MERIT FOR INVENTIVENESS), but also as a confirmation of our company's financial transparency and special achievements for the economy (BUSINESS GAZELLES), diligence in providing services, and an impeccable reputation among customers and business partners (TRUSTWORTHY COMPANY). HSBC Bank placed SECO/WARWICK in the top group of companies developing their business in the international arena and awarded us the title of Hidden Champion, while the title of EXPORT BRAND is proof of recognition for the company's developmental efforts on international markets.

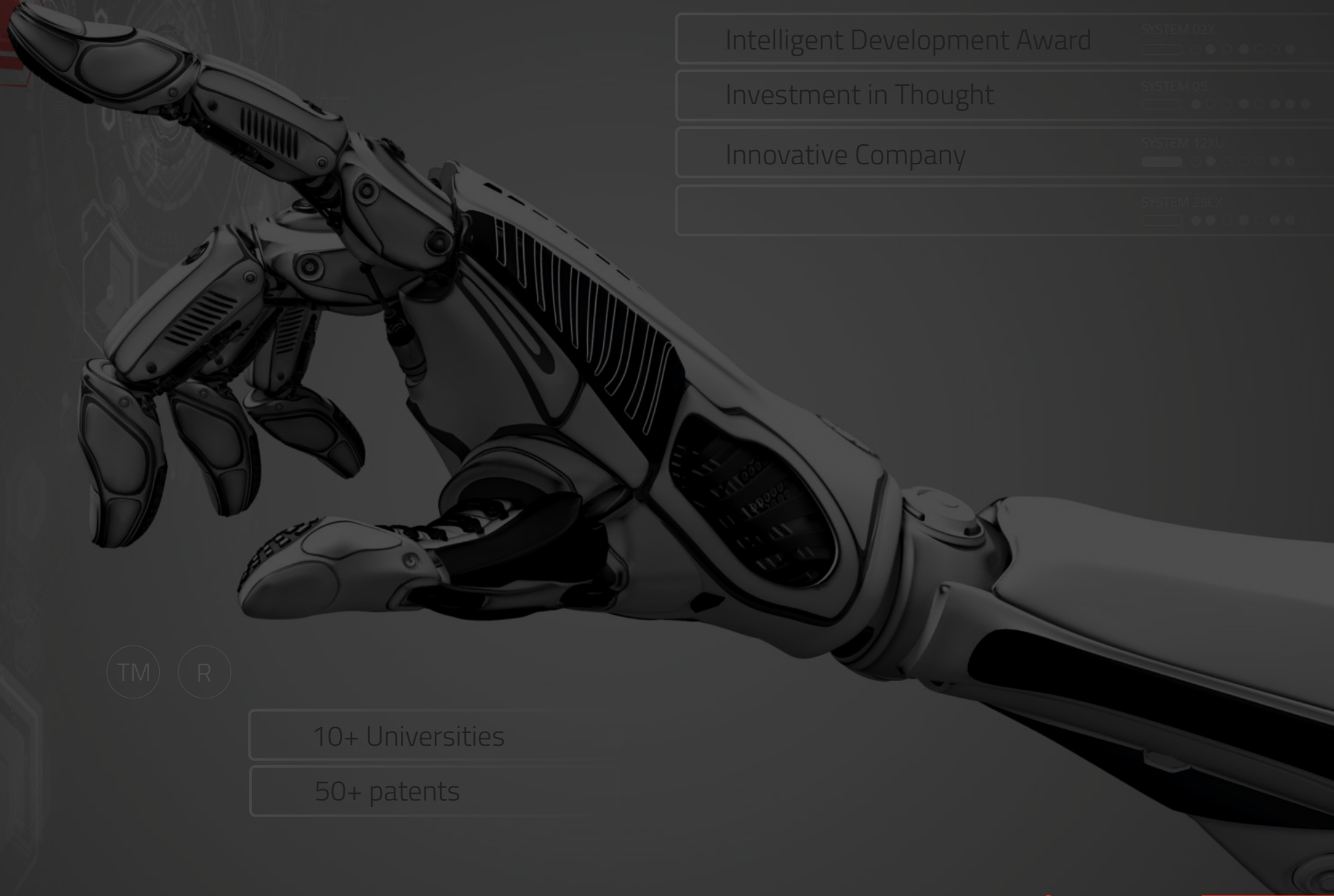

Intelligent Development Award



Investment in Thought



Innovative Company

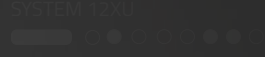

TM R

10+ Universities

50+ patents

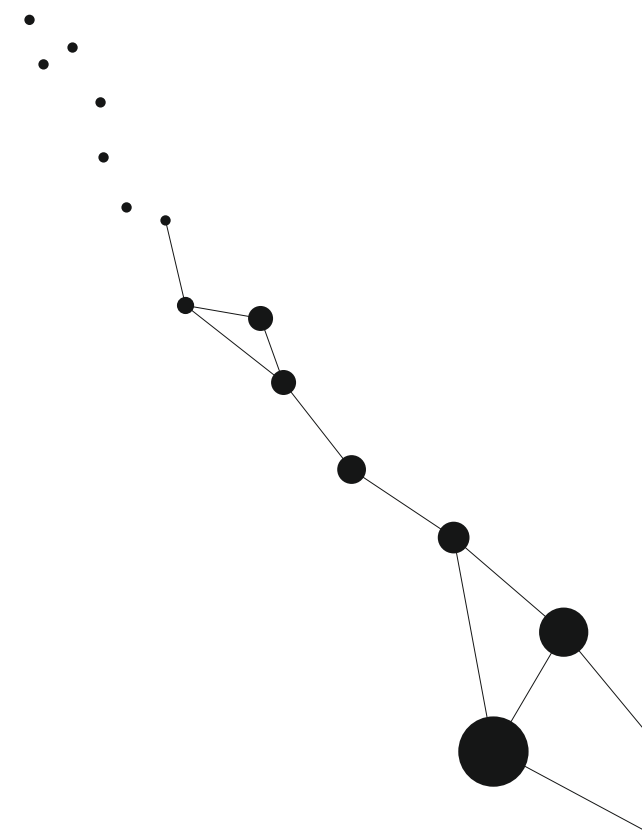

WE DEFINE TECHNOLOGIES

However, it is the needs of our customers that sets a new path for the development of SECO/WARWICK and our products. Research and development projects, laboratories, and world-class scientific personnel are the people who work with our engineering staff to create solutions that will support our customers in the most effective manner. To us, innovation has many names.

Our R&D department conducts its own unique research, full metallographic testing, develops technologies both obtained and purchased, and, together with product departments, creates unique solutions. At R&D, we look for innovative solutions, analyze structural and technological issues, and optimize processes by implementing the latest developments of science and technology. We do all of this to meet the needs of the market and individual customers.

Our own metallographic laboratory (SECO/LAB®) enables us to carry out advanced research including the analysis of metal structures observed on appropriately prepared samples at high magnification.



SECO/LAB®

SECO/LAB® means fast and professional process tests whose conclusions help to develop and optimize processes – essential if one wishes to win based on advanced technology instead of low prices.

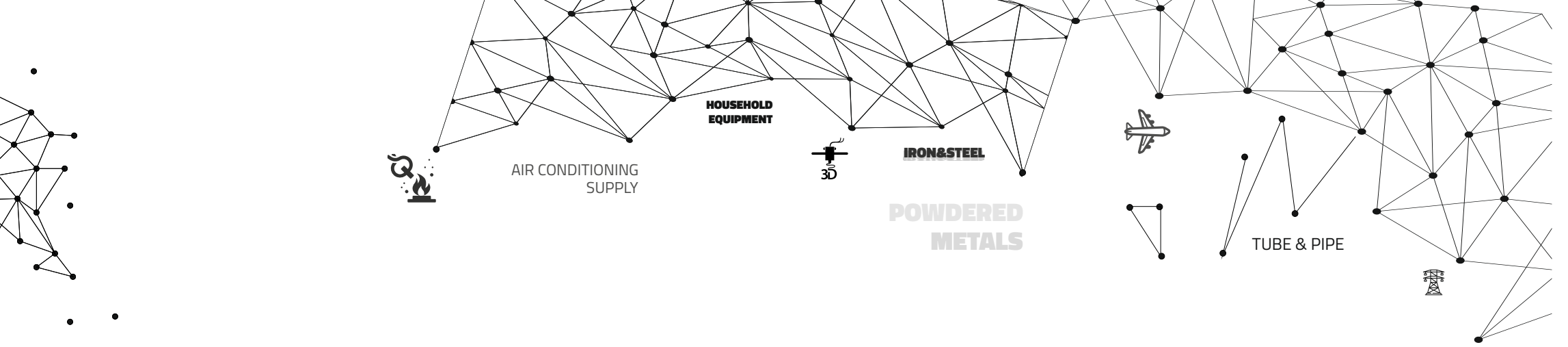

WHO WE BUILD FOR

We supply technologically advanced furnaces to the world's leading industries. 70% of the customers for SECO/WARWICK's solutions are demanding industries and globally recognized brands.

AVIATION

We cooperate with almost all the major players in the aviation sector. One could say that SECO/WARWICK has its modest share in the vast majority of passenger aircraft production. For this industry, we provide solutions for the manufacture of plane engine blades, heat exchangers, turbine blades, aluminum coatings, landing gears, and brakes, fasteners and other critical components.

AUTOMOTIVE INDUSTRY

The automotive industry uses heat treatment to manufacture gearwheels, bearings, shafts, rings, and bushings. The most important thing for this industry is the reliability of the solutions, their efficiency, and repeatability of processes. Therefore, solutions proposed to this industry must consider the need to reduce deformations, lower process costs, shorten the cycle time, apply effective and efficient carburization, and reduce CO2 emissions.



FASTENERS

MACHINERY



POWDERED METALS



COMMERCIAL HEAT TREATMENT

Service hardening plants are one of SECO/WARWICK's main partners who we have been working with for decades. Our equipment operates as the machinery of both large commercial hardening plants and smaller local operators. To this industry, operational efficiency characterized by shorter production cycles and low production costs is crucial. Powered by SECO/WARWICK's equipment, commercial service hardening plants process tools and dies, gears, pipes, heat exchangers, jet engine components, gas turbine parts, and fuel systems, to name just a few of the components that require heat treatment.

POWER INDUSTRY

The power industry is the fourth key customer for SECO/WARWICK Group's equipment. The power industry uses metalworking furnaces to manufacture dies, tools, heat exchangers, and pipes. Though gas turbines are a mature technology, there is always room for improvement. SECO/WARWICK's solutions help to manufacture Plate & Bar heat exchangers, aluminum heat exchangers for air conditioning and the refrigeration industry, along with exchangers for condensing water vapor. We actively participate in projects related to renewable energy sources.

Other important industries that actively take advantage of the solutions offered by SECO/WARWICK include medicine (manufacturing of medical instruments, implants, biomedical engineering), the tool industry (dies, aluminum profiles), and 3D printing (prototypes, metal powders, additive manufacturing). Each year, the number of applications for SECO/WARWICK Group equipment grows because engineers work to ensure that it meets the needs of the changing market. Because of this fact, the list of industries with which the Group cooperates always stays open.



CUSTOMERS ARE OUR REFERENCES

Our mutual commitment

See who has trusted us. Customer reviews are the best recommendation.

"SECO/WARWICK's strengths lie primarily in its ability to apply innovative designs meeting non-standard requirements."

"We choose technological partners who take on the most difficult tasks expected of equipment today. What matters to us is the stability and continuous operation of equipment over many years, which SECO/WARWICK Group guarantees."





"In our many years of cooperation with SECO/WARWICK, we value process and maintenance support the most. The technological knowledge and individual approach of SECO/WARWICK engineers to challenges is, in our opinion, as valuable and unique as our products."

"We decided to partner with SECO/WARWICK because of this company's innovative thinking and established position on the market. The number of projects and implementations as well as the scale of activities are truly impressive."

"Our team of specialists values the cooperation with SECO/WARWICK experts and technologies. We expect solutions of the highest quality due to the demanding requirements of the aviation applications that we work with. SECO/WARWICK's experience and profound knowledge helps us keep our promises. This is a true partnership."

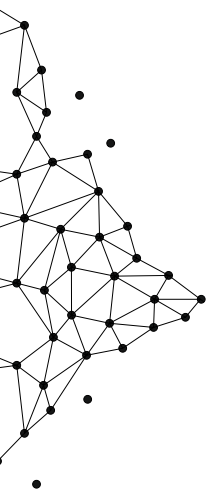

TEAM = VALUE

We believe that apart from technology and a good strategy, the decisive factor for our advantage over the competition is our people, in other words, the team. It is the team that started the company years ago, and it is the team that continues to give us the edge. The power of the team, its ability to do practically anything, and its knowledge mean that the SECO/WARWICK Group continues to set trends rather than follow the beaten track.

We operate on all continents and provide a global team of experts. Thanks to the experienced international team, mutual understanding, dialog, communication, and an efficient exchange of information, we live up to our customers' high expectations.



750 EMPLOYEES

AVAILABILITY ON 5 CONTINENTS

100 MAINTENANCE ENGINEERS

IN 7 COUNTRIES

60% OF OUR PERSONNEL ARE ENGINEERS

33 THE AVERAGE AGE

OVER 4000 SOLUTIONS

14% ARE WOMEN

WE SPEAK 7 LANGUAGES

CUSTOMERS IN 70 COUNTRIES

A PARTNER ON A GLOBAL SCALE

- International Branches of SECO/WARWICK
- Solutions provided by SECO/WARWICK

SECO/WARWICK

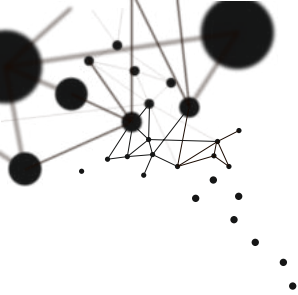

WE HAVE VALUES IN OUR DNA

SECO/WARWICK's values are like human DNA. They were created when the company was conceived from the vision and values of its founders. They formed a DNA chain whose basic genotype is DEVELOPMENT of both ourselves and our partners. This fundamental trait enables us to innovate by expressing our values in new business models, organizational designs, and offers – our organization evolves and changes over the course of its life, expressing itself differently depending on the environment.

While, in nature, it is the genetic compatibility between the donor and the recipient that determines whether the joining of two organisms will be successful, at SECO/WARWICK success is the ability to match our DNA of values with business strategies and with the market.

INNOVATION



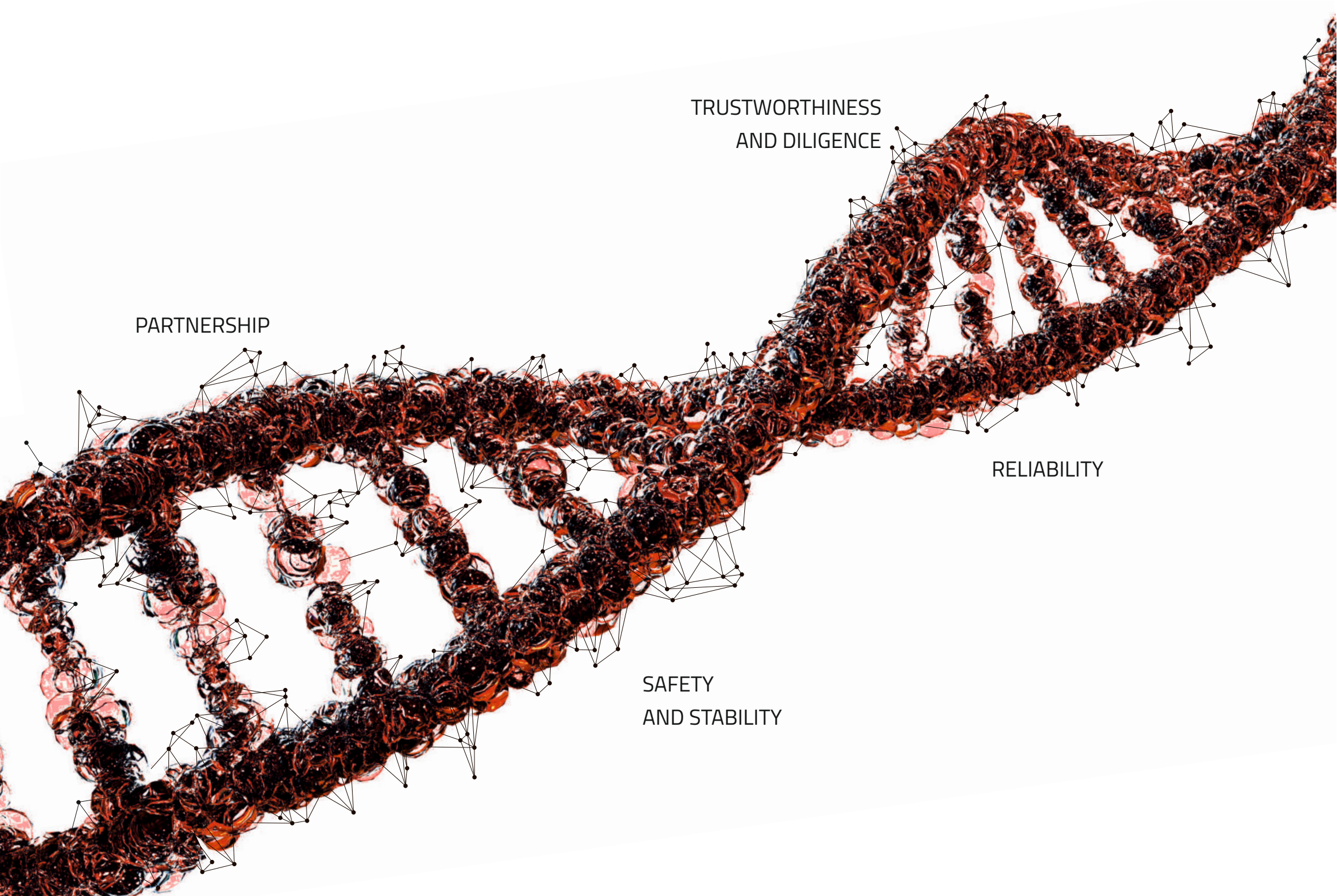

TRUSTWORTHINESS
AND DILIGENCE

PARTNERSHIP

RELIABILITY

SAFETY
AND STABILITY

OUR VALUES

SECO/WARWICK not only creates but also develops heat treatment and vacuum metallurgy technologies. But we do not limit innovation to creating modern furnaces or technologically advanced production lines.

We understand **INNOVATION** as activities that lead to creating new or improved products, processes, technologies, and organizations. Knowing that innovation is everywhere, we want it to be evident also in our thinking, approach, and creation, in every place in the world, every position, and every action. When establishing relations with our customers, suppliers, and employees, we first and foremost think of the interests of the other party. To us, **PARTNERSHIP** is therefore a mutual commitment based on respect and responsibility, and we treat feedback as part of our development because it ensures the **SAFETY AND STABILITY** of the reliable products that we deliver. But the chain of creation involves people, for whom we want to ensure work stability and continuous development, while for our partners we want to be predictable and safe in terms of business in the long run. Because partners should never be let down! This is why **RELIABILITY** is another one of our values. We do not fail as people, partners, or technology providers. This makes us **TRUSTWORTHY AND DILIGENT**, which are some of the key challenges facing the global business community.



RELIABILITY

TRUSTWORTHINESS AND DILIGENCE

PARTNERSHIP

INNOVATION

SAFETY AND STABILITY



SOCIALLY RESPONSIBLE

Being an entrepreneur does not limit us to selling products or services. We support the initiatives undertaken by residents, employees, and community organizations that we believe are right and in line with our values and objectives.

In terms of Corporate Social Responsibility, business defined and represented by SECO/WARWICK is:

- + responsible, including social responsibility,
- + a partnership with customers, employees, society, families,
- + in tune with reality, including close (local) reality and surrounding reality,
- + practices internal and external transparency,
- + consistent in action, approach, and thinking,
- + has a heart for people (families) and for the environment.

It deserves to be mentioned that our activities are carried out not only in response to requests or appeals from NGOs, but also those from individual people and public interest establishments. Employees from the CSR team analyze the needs of the various stakeholders and select initiatives in which we want to be, and should be, involved.



reality

heart

transparency

partnership

responsibility

consistency



WE SUPPORT

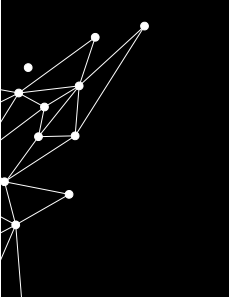

Not just socially. We also support our customers in maintaining the continuity of production, because it is the priority of every production company. Every user of an industrial furnace wants to minimize the risk of failure while maximizing their certainty of this equipment operating effectively.

This is why SECO/WARWICK has divided industrial furnace services into two main groups: traditional maintenance services that include reactive and preventive maintenance, and services related to the possibilities of Industry 4.0 that include proactive and predictive maintenance.



A NEW DEFINITION OF
MAINTENANCE SERVICES

SECO/WARWICK

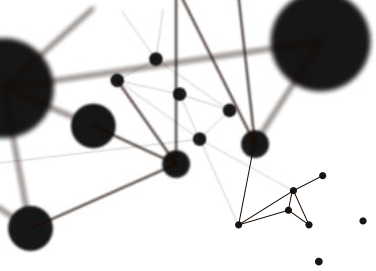

TAILORED TO YOUR NEEDS

We know and understand equipment, which is why SECO/WARWICK increases equipment availability through automated maintenance processes and provides construction services and technological support during overhauls, upgrades, and relocations. We also carry out preventive inspections and the resulting preventive measures, warranty and post-warranty repairs, regular and/or periodic testing, maintenance work, and operator training.

With SECO/WARWICK, the phrase 'professional maintenance services' means more than just a repair in case of failure. It means reaction, support, speed, readiness, dialog, and availability, regardless of the brand of the equipment. The experience of our maintenance team allows us to offer comprehensive maintenance services for furnaces of various brands.



SECO/WARWICK assumes responsibility
for the operation of your equipment,
leaving you time for strategic planning.

SECO/WARWICK

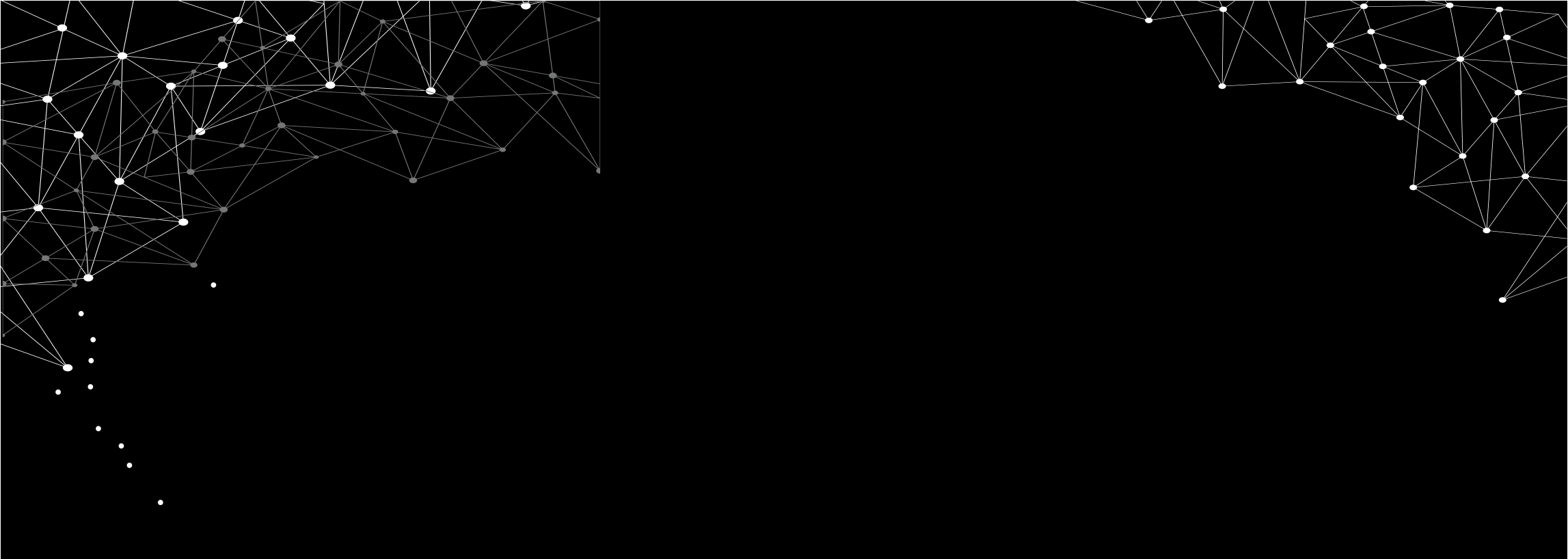

The SECO/WARWICK maintenance team stands for quality, knowledge, and experience, allowing you to manage your heat treatment machinery in a planned and professional manner.

The common misconception of the work of a maintenance department is to be summoned to fix a faulty machine is no longer good enough. Today, maintenance strategy is a whole field of knowledge that the market's best companies implement to suit their customer's needs. Fully professional maintenance services encompass the stages of technical designing or upgrading of equipment, developing user and maintenance personnel manuals, ensuring availability of equipment operation at the required level (SLA), maintenance programs, advanced prevention techniques, and rapid response in case of failure. SECO/WARWICK sets trends in this field by implementing solutions that are not commonly available on the market. Using new technologies, it offers dedicated programs related to increasing availability, increasing efficiency, and reducing costs.

Global **Local service**



USA



Germany



Poland



Russia



India



China

INVENTION MEETS RELIABILITY

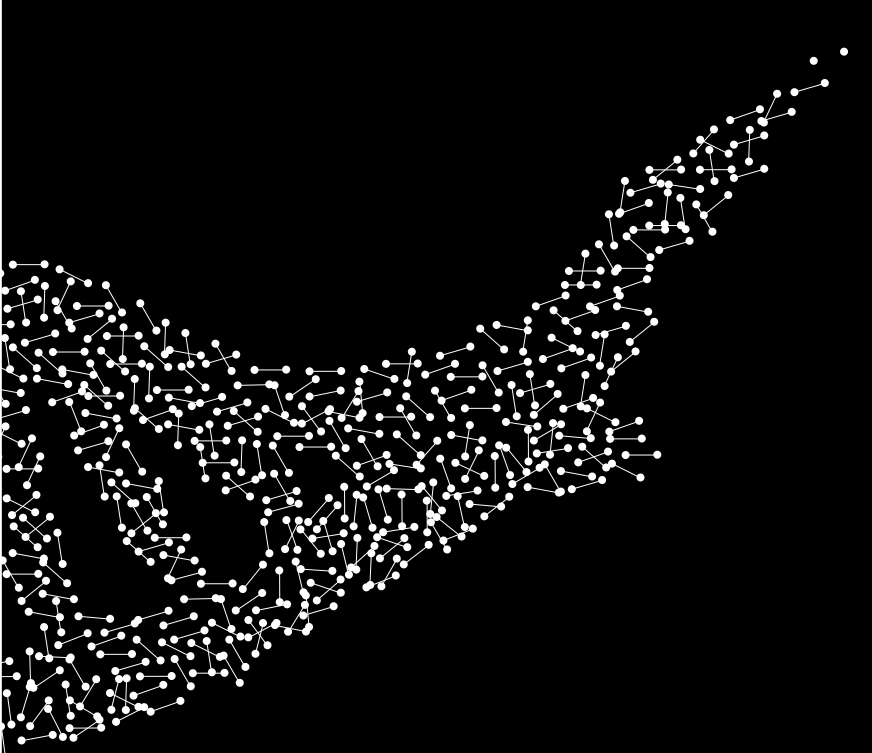

SECO/WARWICK's DNA is in every product, solution, strategy, and project. It is what makes us different and what gives our customers an advantage.

It allows SECO/WARWICK to be the metal heat treatment market leader – an innovator who, together with numerous research institutes, defines new solutions and offers equipment with modern technology, tailored to needs, possibilities, and objectives of our customers. Efficient logistics, delivery, assembly, and start-up of equipment, maintenance in every corner of the world, technical and process training, an international team of experts and specialists. All these things result from the need for never-ceasing development that has been etched into the company's DNA from the very beginning of its existence and still is – in every moment and in every thought.

Thanks to SECO/WARWICK's DNA and the values encoded within, the company continuously achieves spiraling growth and is truly the company where ... **INVENTION MEETS RELIABILITY.**

INVENTION MEETS RELIABILITY

SECO/WARWICK

WWW.SECOWARWICK.COM