

The logo for SECO/WARWICK, featuring the company name in a bold, italicized sans-serif font. A red diagonal line separates the 'SECO' and 'WARWICK' parts of the name.

SECO/WARWICK

INVENTION MEETS RELIABILITY



CAB Systems

Controlled Atmosphere Brazing for manufacturing aluminum heat exchangers



SECO/WARWICK the manufacture of heat treatment equipment has developed and provide wide range of CAB equipment on the market. Due to continues improvements and innovative solutions of brazing equipment **SECO/WARWICK CAB** becomes a global leader of CAB equipment on the market.

ALUMINUM BRAZING

SECO/WARWICK is one of the world's most experienced and innovative furnace manufacturers with hundreds CAB Brazing Systems installed worldwide. Our commitment to quality products begins in engineering and continues through the complete installation of your system, including aftermarket support. ISO 9001 certification in our global manufacturing facilities ensures our high-quality standards are adhered to throughout the manufacturing process.

Controlled atmosphere brazing of aluminum (CAB), using a noncorrosive flux, is the preferred process for manufacturing aluminum heat exchangers.

Since entering this field in 1983, SECO/WARWICK has led the development of advanced technology in the continuous flow brazing process.

Capitalizing on over 100 years of furnace design experience, SECO/WARWICK has driven innovations such as:

- / Improved muffle design.
- / convection heating technology continuous atmosphere control systems.
- / ACCUBRAZE® PC/PLC controls.
- / Prioritized heating control systems including sinuous loop and gas fired systems.
- / Energy saving designs.
- / System rebuilds and upgrades.
- / Feasibility studies.

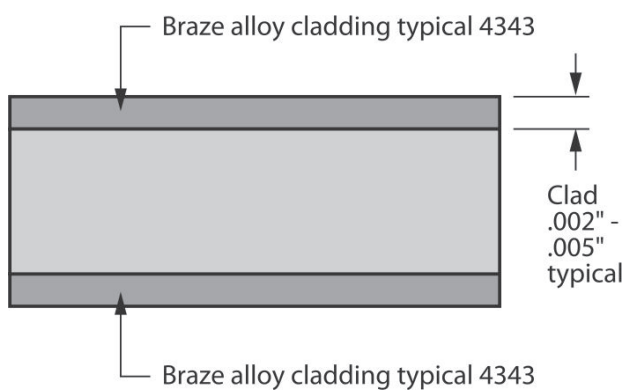

Figure 1

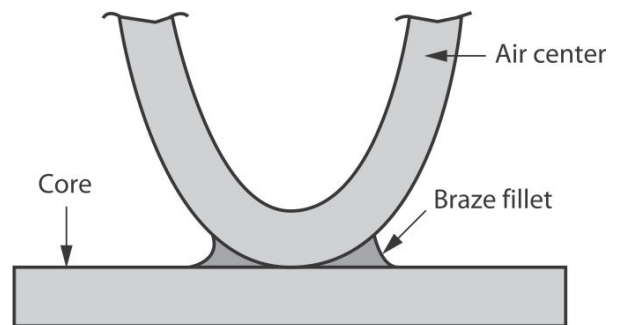

Figure 2

- / Accepts a less demanding dimensional fit-up.
- / Flux is noncorrosive.
- / Requiring no post braze cleaning, less capital intensive compared to vacuum brazing.
- / Continuous flow for high volume throughput.

These innovations, along with others, have led to the design of a variety of brazing furnace systems to meet the growing demand for aluminum brazing. Each of these systems provides unique benefits based on the size and scope of a manufacturer's individual brazing needs.

Controlled atmosphere brazing of aluminum (CAB), using a noncorrosive flux, is the preferred process for manufacturing aluminum heat exchangers. Since entering this field in 1983, SECO/WARWICK has led the development of advanced technology in the continuous flow brazing process.



ADVANTAGES

The controlled atmosphere brazing (CAB) process heats a product to brazing temperatures while maintaining uniform temperatures within the product in an oxygen-free nitrogen atmosphere.

During furnace brazing, a brazing sheet (figure 1) of aluminum/silicon alloy plate (cladding) is heated to a liquid state and flows to form aluminum joints or fillets. A sample of a fillet is shown in (figure 2).

Although heat exchangers such as battery coolers, radiators, condensers, oil coolers, evaporators, heaters, and charge air coolers for the automotive industry dominate current demand, other applications continue to lend themselves to aluminum brazing.



CONTROLLED ATMOSPHERE BRAZING PROCESS

A fully configured standard CAB furnace system includes a thermal degreaser, a fluxer unit, a dry off oven, and the CAB furnace. These systems can be configured in an in-line, a continuous rectangular line, or a U-shaped line to meet your plant's installation space requirements.

Thermal Degreaser

A Thermal Degreaser Oven will thermally remove the lubricating oils present on the heat exchanger from prior fabrication stages. The assembled and fixtured product will be placed on the oven conveyor for processing. The oven will typically operate at 150-300°C to vaporize the oils. If light evaporative oils are used in the process, the vapors from the products are oxidized in the combustion chamber. If heavier

lubricating oils are used, an incinerator at the oven exhaust may be required. The products must then be cooled back to ambient temperature prior to the fluxing process.

Incinerators

Thermal degreaser ovens are usually equipped with the equipment for reducing the VOC emission to the legal limits. The standard solution for this process is the thermal incinerator where the oil vapor is burned in high temperature. The thermal incinerator is usually installed with a kind of heat recovery system to reduce the energy consumption.



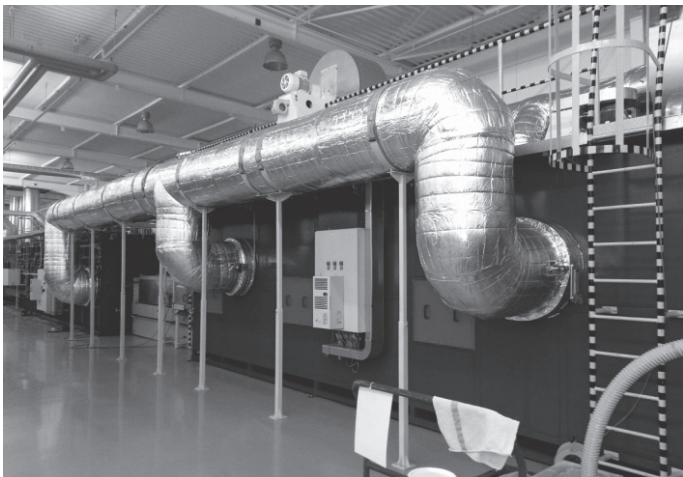

Flux Application

The spray nozzles apply the flux mixture directly to the body part or header as your specifications require.

Once applied, a series of adjustable, powerful air knives, positioned over and to the sides of the conveyor, strip away the excess flux from the part. The complete system includes necessary pumps, strainers, inlet and outlet pressure gauges, adjustable discharge spray manifold headers and nozzles, portable stainless steel flux tote with agitators, an air knife, a mist eliminator and exhaust fan, a variable speed conveyor drive, and all the necessary piping to make a single connection complete with valves.

Products requiring internal fluxing will require special consideration depending on the heat exchanger design.

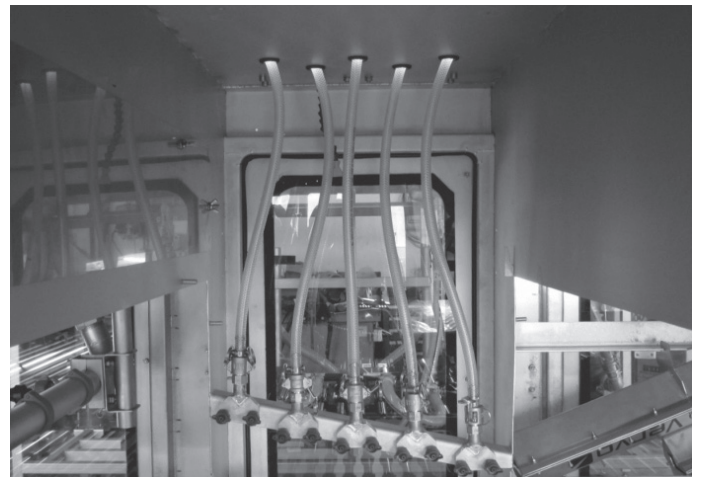

Dry Off Oven

The dry off oven is the final preparation before brazing. The oven's internal components are constructed of stainless steel to ensure a long working life.

Heat is provided by electric, propane, or a natural gas fuel source. Heat recovery the parts are conveyed into the oven, where they are heated and dried prior to brazing. The air is heated in an air supply chamber and then forced up through the work. The hot air is collected at the top of the oven and recirculated back to the heat source for use in the oven again. All duct work and fans are constructed of stainless steel.

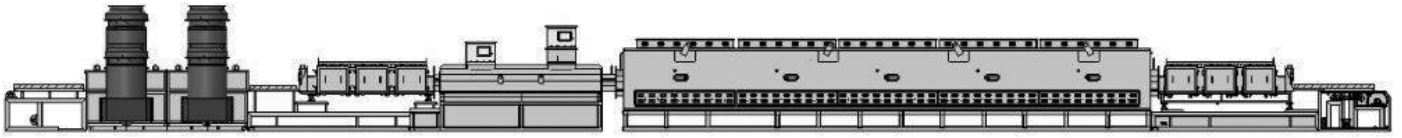

RADIATION CAB FURNACE

A radiation braze CAB furnace is an ideal method for brazing similar size products in a continuous flow environment. If you intend to produce a single or only a few variations of that product, a radiation furnace system makes sense.

This furnace is designed to use a heated muffle to braze the product. Our design includes proportionally controlled electric heating elements to heat the muffle, which in turn provides the radiant heat to the products.

Natural gas fired combustion systems also available. Temperatures are controlled uniformly throughout the length of the furnace by several independently heated zones.

Muffle design is quite important to the overall efficiency of the system. SECO/WARWICK manufactures its muffles with the high level of craftsmanship the process demands. Radiation CAB furnaces are very efficient with respect to the consumption of the nitrogen atmosphere and require less maintenance compared to the other CAB methods.

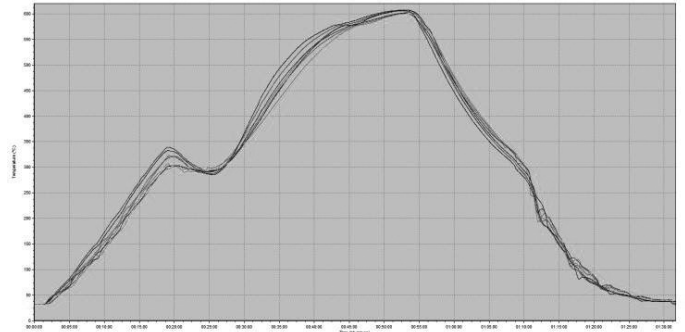
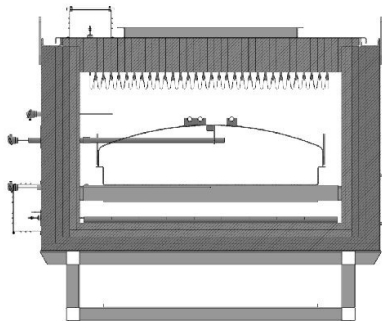

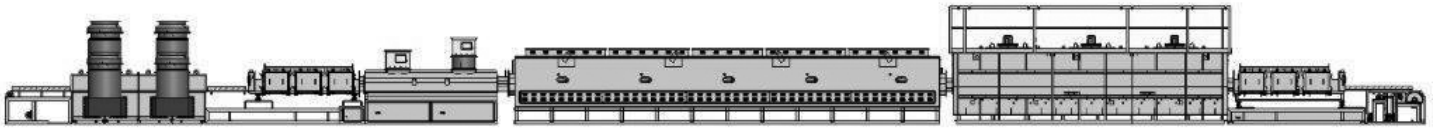

CONVECTION / RADIATION CAB FURNACE

When your brazing needs are more diverse, a combination convection preheating and radiation brazing furnace system could be your answer.

The addition of convection preheating improves the furnace's overall flexibility, enabling manufacturers to run product of different mass and dimension in the same cycle. This

type of system is more forgiving when running production intermittently.

The initial heat zone, uses both convection and radiation heat to uniformly preheat an assortment of products. Once preheated, the product moves into the radiation brazing section, where the product is brought to and held at a uniform temperature to allow the clad materials to melt and form a joint. All of our continuous CAB furnaces use a variable speed drive and a stainless steel mesh belt to move product.

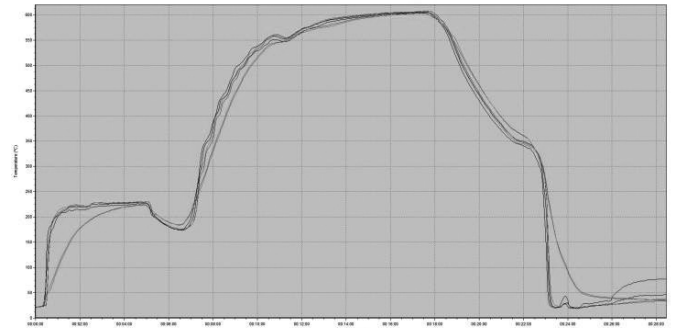
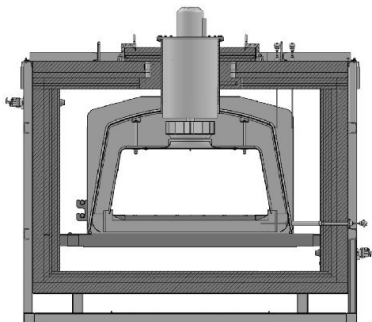

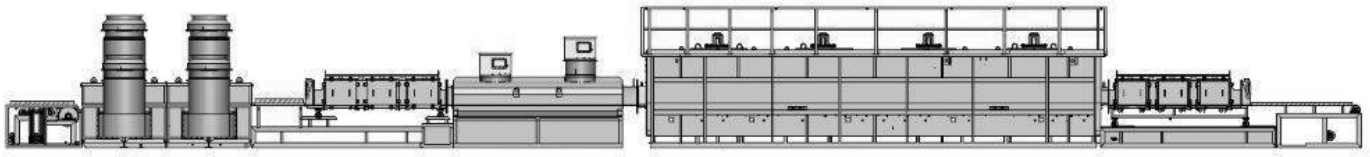

CONVECTION CAB FURNACE

A pure convection heat controlled atmosphere furnace system is the most efficient means to braze a wide variety of products in the shortest possible cycle time.

SECO/WARWICK convection furnaces maintain excellent temperature uniformity to within 3 degrees C. Convection heat transfer is used to bring the entire part to brazing temperature in a recirculated nitrogen atmosphere. A convection system takes less floor space due to its shorter overall length when considering furnaces of similar production throughput. Cycle heating times can be as low as 5 minutes, while mixing loads

with diverse products.

These furnace systems are popular in the automotive industry where installation space requirements are at a premium and intermixing of various size products is the norm. Convection systems show great promise in emerging applications, making them a solid investment for the future. A convection CAB furnace is the most efficient means to braze large heat exchangers used in the heavy duty and off-road industry. This is also a solution for the requirements of extra short cycle time.

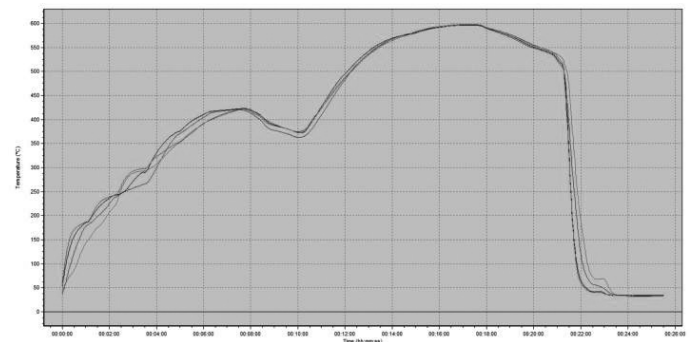
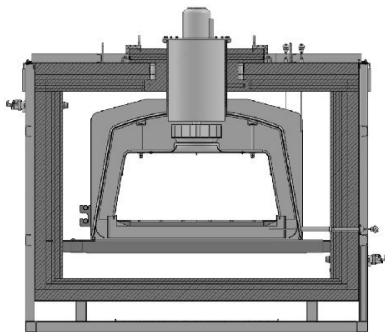

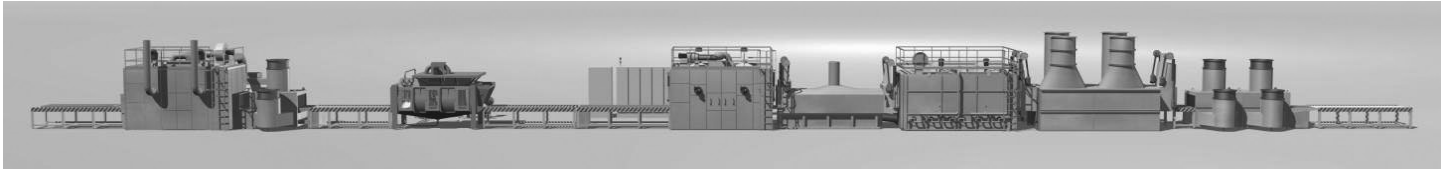

ACTIVE ONLY® CONVECTION CAB FURNACE

The Active Only furnace system is designed to operate on a part-time basis.

The furnace can be brought up to brazing temperature from ambient and conditioned with a proper atmosphere in a very short time. This semi-continuous system allows for variable heating and cooling rates, depending on indexing times. This furnace can braze the widest variety of heat exchangers with lower production requirements. Our Active

Only furnace is based on a six step indexing cycle. The six indexing positions include the load table position, the dry off oven, the entrance purge chamber, the patented convection brazing chamber, the air jacketed cooling chamber and the airblast chamber.

The product runs in a horizontal position with an infinitely adjustable dwell time based on the hearth load and load configuration. A thermocoupled work zone monitors recovery time when the load is run intermittently. This system includes innovative features to improve brazing efficiency. The furnace ensures a uniform heating of product through a patented muffle configuration. The stop and go indexing working mode ensures a very short time of product transportation between cold and hot zones. It is especially important for a big size HVAC condensers and battery coolers.

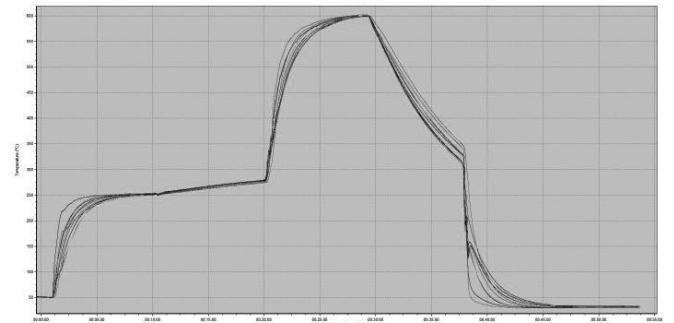
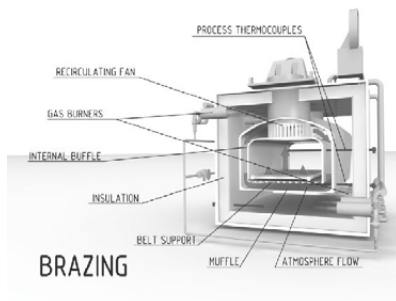

VERTICAL BRAZING CAB FURNACE

A uniquely designed version of an „Active Only” indexing furnace has been developed, where the brazed elements are positioned vertically.

For some types of heat exchangers such like plate and bar vertical orientation provides benefits as the cladding melts. It allows the joints to be evenly filled on a horizontal plane.

This prevents the brazing alloy from accumulating on one side of the heat exchanger chamber but also from the internal openings of the heat exchanger. This feature is especially important for the paint fluxed products.

Vertical position is beneficent also for proper tensioning of the big size plate and bar heat exchangers. Additionally, the furnaces that are utilizing the vertical brazing position are also using a vacuum purge.



This solution has limited the nitrogen consumption and has definitely improved furnace atmosphere cleanliness.

Due to vacuum flushing in the furnace vestibule, air is removed not only in the chamber but also from the internal openings of the heat exchanger. This feature is especially important for the paint fluxed products.



VACUUM PURGE CAB FURNACE

For prototyping low volume brazing

The vacuum purge one chamber batch CAB furnace is an advanced hot wall, front loading retort furnace with vacuum purging especially designed for R&D aluminum brazing.

The standard furnace hot zone is 600 mm x 600 mm x 900 mm (24" x 24" x 36"), however SECO/WARWICK can custom engineer furnaces to suit the application.

This furnace has a compact design with an internal recirculation fan and external cooling air blower.

The packaged furnace system consists of the heating system, vacuum pumping system, nitrogen system and atmosphere controls.

The brazing cycle begins with vacuum purging of the stainless steel retort with N₂ backpurge, followed by fast and uniform heating up to brazing temperature. When the soak cycle is complete, the cooling cycle is initiated.

The advantage of a vacuum purge batch furnace is that it is always ready for work at room temperature and it is cold when the cycle is completed. No pre-heating is required. This special design enables precise control of the heating and cooling speeds during the entire cycle. Atmosphere conditions like oxygen and/or dewpoint can be set on the defined level.

This batch type furnace allows the user to simulate a wide range of brazing conditions that would be experienced in a continuous furnace.

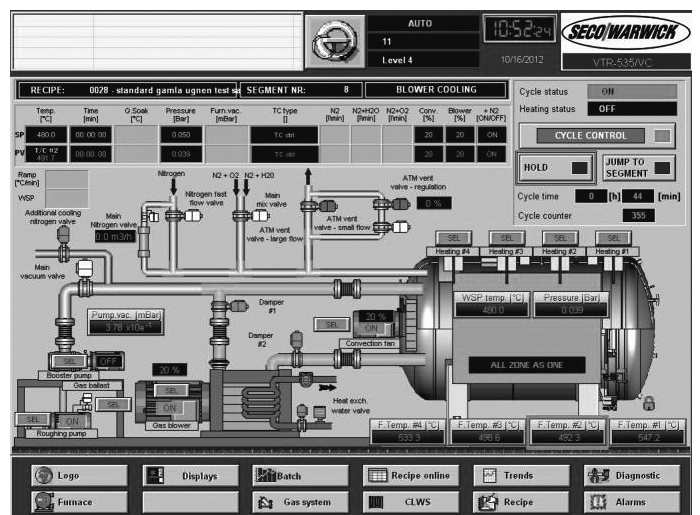
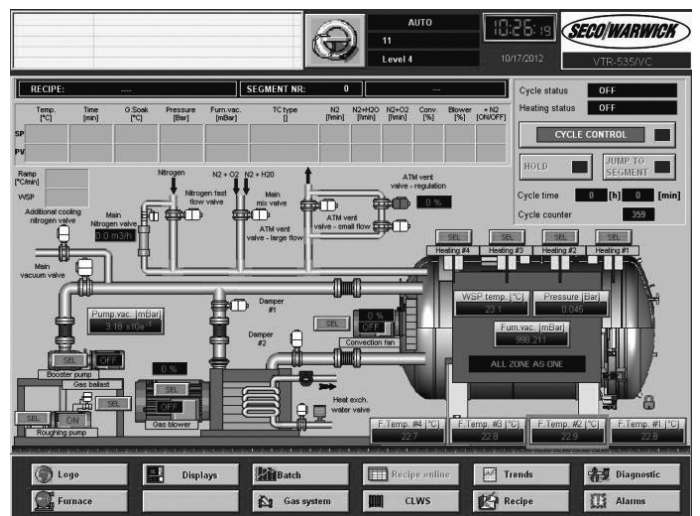
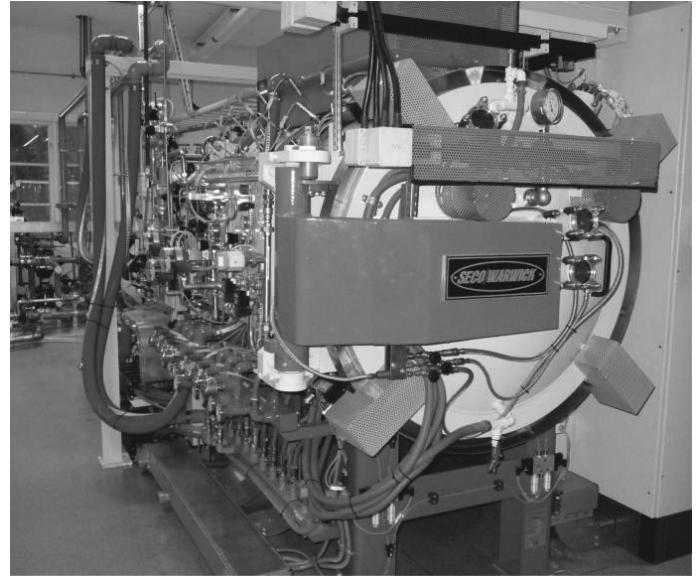

UNIVERSAL CAB BATCH FURNACE

High brazing quality for low volume producers

The Universal CAB Batch Furnace is designed to braze the widest variety of heat exchangers in horizontal or vertical position depending on the product design requirements. It operates on a parttime basis.

The furnace can be brought up to brazing temperature from ambient and conditioned to a proper atmosphere in a very short time.

This two-chamber batch system allows for variable heating and cooling rates, depending on product requirements.

The design of the Universal CAB Batch furnace is prepared for the future upgrading to the three chamber equipment.

This is the most economical way to increase the output of the existing CAB system.



INDUSTRIAL APPLICATION

- / For all types aluminum heat exchangers.
- / Horizontal and vertical brazing availability.
- / Ideal for low volume HEX producers.
- / Dedicated for the Plate&Bar heat exchangers This two-chamber batch system allows for variable heating and cooling rates, depending on product requirements.





ADVANTAGES

- / Highest flexibility.
- / Short preparation time (2-3 hours).
- / Low Nitrogen consumption.
- / High brazing quality:
 - / Clean atmosphere -Optional Vacuum purging,
 - / Temperature uniformity,
 - / Sharp heating profile,
 - / Repeatable brazing process.
- / Compact design.
- / Easy for installation and use.



OPTIONS

- / Build in line together with degreaser fluxer, dryer.
- / Compact design easy for installation and use.
- / Low investment cost.

VACUUM PURGING SYSTEM

- / Two stages vacuum pumping.
- / Vacuum down purging to the pressure lower than 0,05mbar corresponds with Oxygen content 10ppm.
- / One time refill by Nitrogen-atmosphere quality below 20ppm.

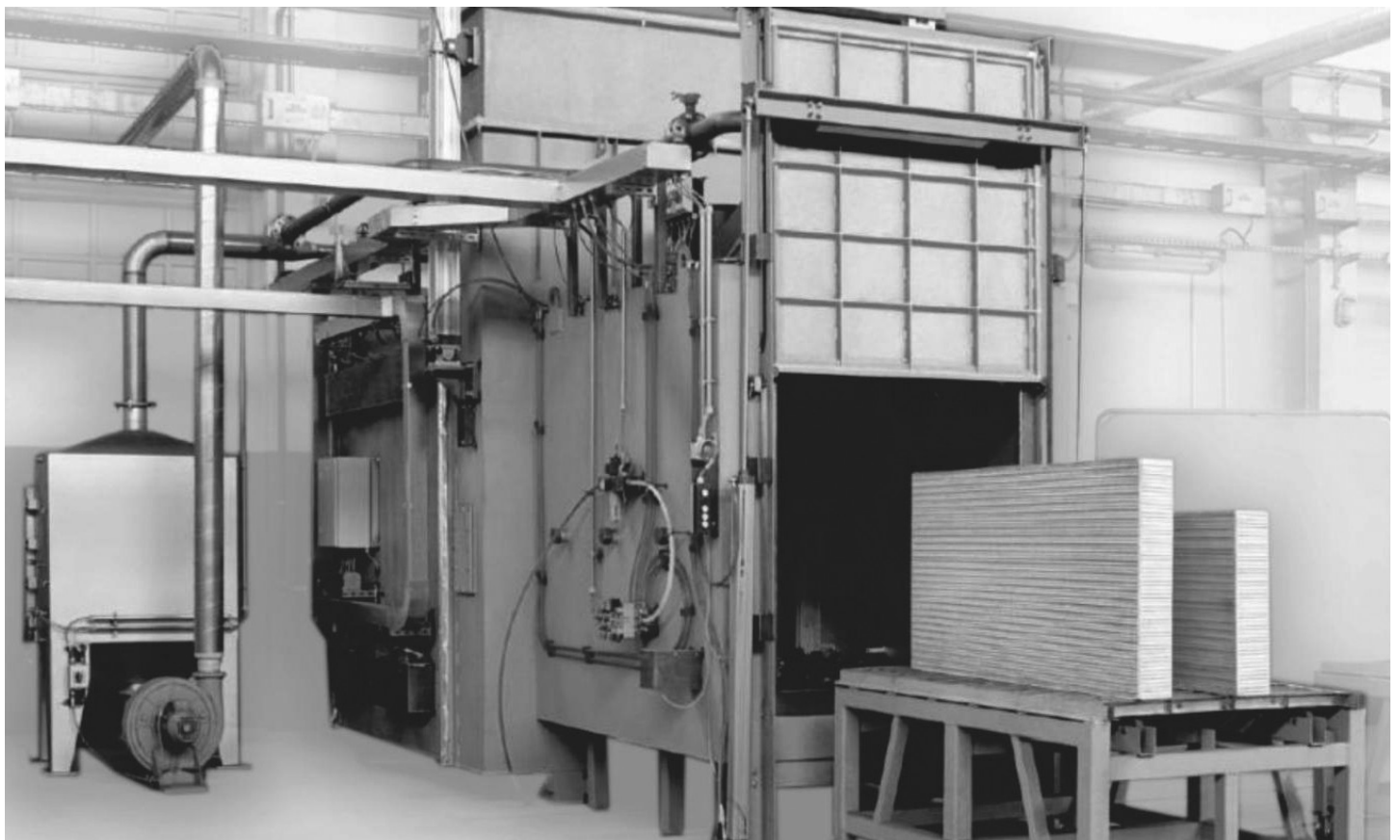
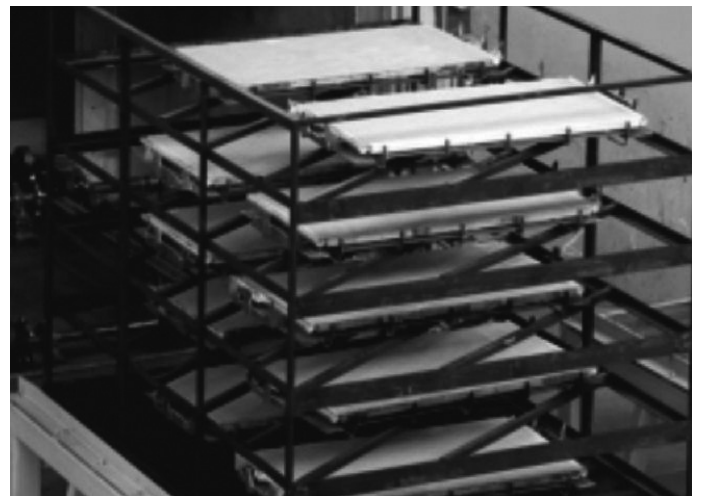

SPARE PARTS AND CAB LINES MODIFICATION

SECO/WARWICK can provide field technical support and replacement parts for all CAB equipment manufactured by both SECO/WARWICK, and Camlaw Ltd. (SECO/WARWICK is the exclusive supplier of CAMLAW CAB equipment service and replacement parts) or others manufactures.

We have successfully provided both parts and rebuild services for other manufacturers as well.

Technicians are available for equipment breakdowns SECO/WARWICK has the knowledge and experience to provide repairs, rebuilds, upgrades, relocating equipment, trouble shooting, and preventative maintenance.



R&D CAB BRAZING CENTER

BRING YOUR CORE.

WE WILL BRAZE IT!

Reduce your investment risk by taking advantage of the SECO/WARWICK Brazing Center. SECO/WARWICK Europe operates a fully equipped Brazing Center to support our customers by allowing them to run trials and prototypes of a wide variety of heat exchangers.

BRAZING CENTER

The Brazing Center is fully equipped with an Active Only CAB Brazing system, wet fluxer, thermal degreasing/drying/debinding/ oven to allow customers to utilize a complete operational manu-facturing cell.

The test furnace can handle loads up to 1500 mm wide x 2500 mm long x 450 mm high (59 inch x 98 inch x 17 inch).

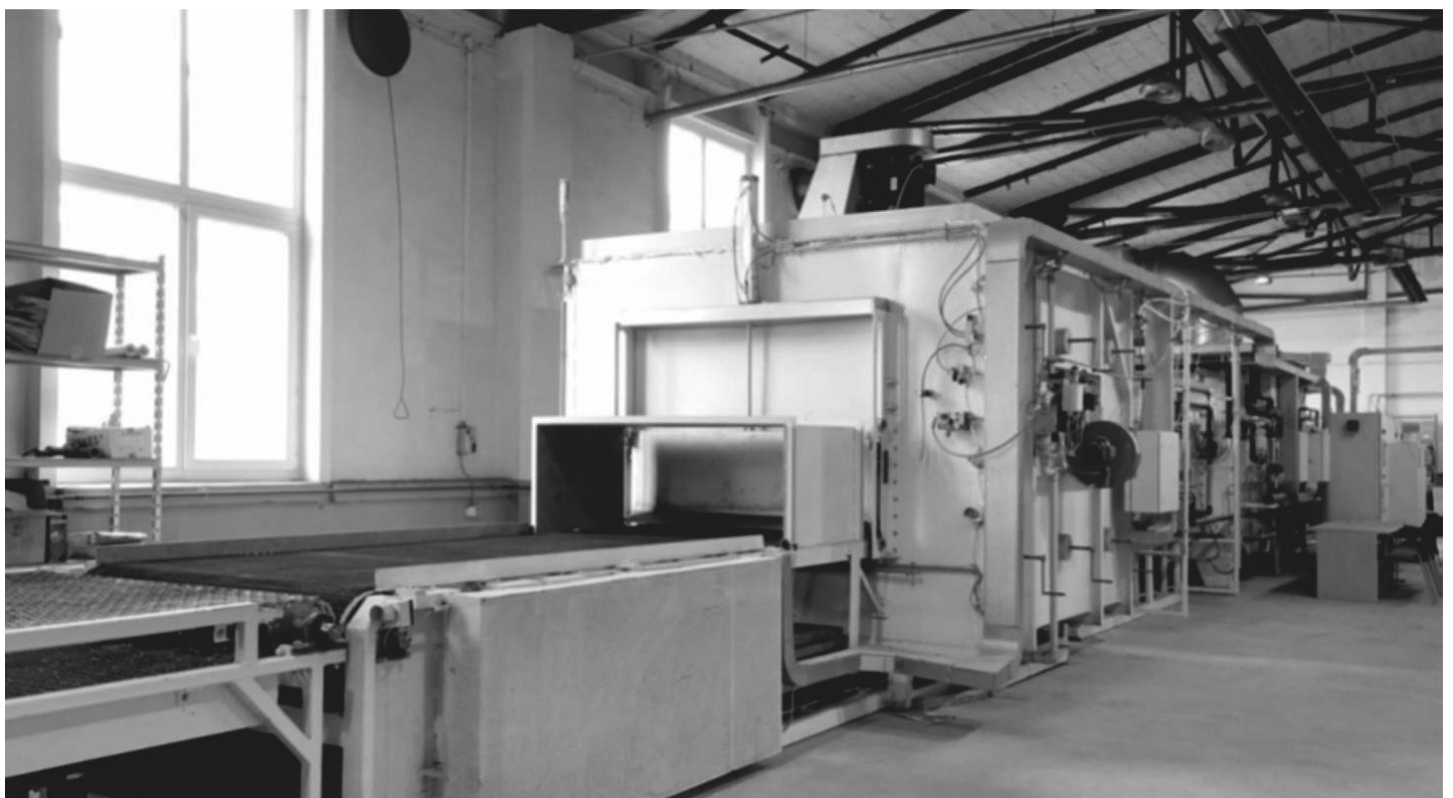



SECO/WARWICK Invention Meets Reliability

SECO/WARWICK is the 1st choice supplier
of solutions for heat treatment and metallurgy.

We create innovative products that provide our customers with reliable, safe and environmentally friendly solutions for heat treatment and metallurgy and ensure the economic efficiency of their businesses. Expertise includes end-to-end solutions in 5 categories: vacuum heat treatment, atmosphere, and aluminum thermal processing, controlled atmosphere brazing of aluminum heat exchangers and vacuum metallurgy.

SECO/WARWICK Group, with 8 companies located on 3 continents, has customers in nearly 70 countries with more than 4000 deployed solutions. The company provides standard or customized state-of-the-art heat processing and metallurgy equipment and technologies to leading companies in the following industries: automotive, aerospace, electronics, tooling, medical, recycling, energy including nuclear, wind, oil, gas, solar and production of steel, titanium, and aluminum.

SECO/WARWICK

WWW.SECOWARWICK.COM